

### Programmable Industrial Protocol Converter:

- ▶ DIN Rail or Panel Mounted compact Protocol Converter
- ▶ Hardware with two communication ports. COM1: RS232 / RS422 / 2 or 4 wire RS485 / CMOS  
COM2: Profibus - DP Slave (2 wire RS485)
- ▶ Connects PLC / Drive on Profibus Network
- ▶ Allows data sharing between PLC, Inverters, Controllers and other network devices
- ▶ Common model for connecting different devices. Several PLC and Inverters can be supported
- ▶ Low power consumption of only 2.5 Watts
- ▶ Common Programming software for the entire Gateway family.....FREE!!
- ▶ CE, CSA and UL certification

## Possible Applications

GWY-500 connects one field device over serial link to another field device over a Profibus network. User can define the blocks of registers to be fetched from one device and to be transferred to the other. Our users have used Gateway units in different applications across many industries. The typical configuration includes the following:

### 1. PLC to PLC Communication



### 2. PLC as slave in Profibus network

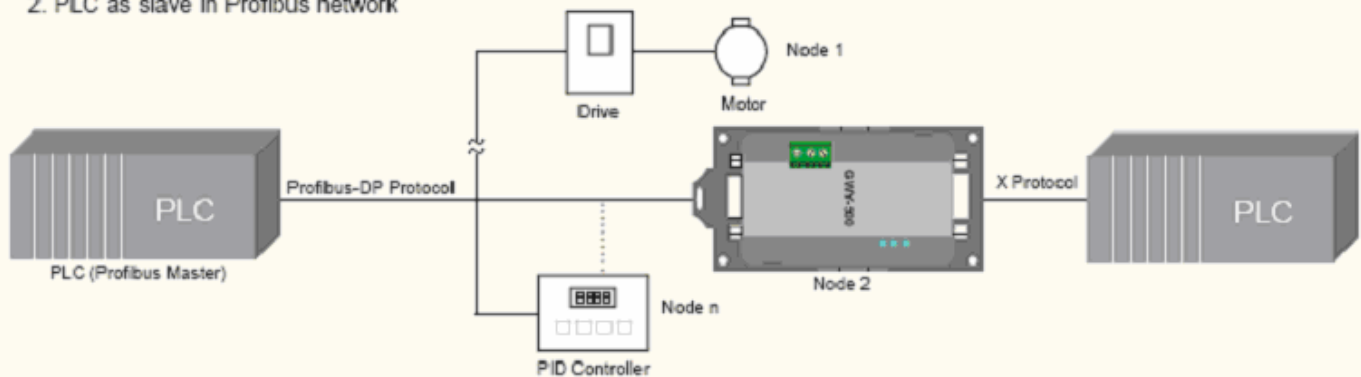

### 3. PLC (Profibus Master) as slave in Modbus network

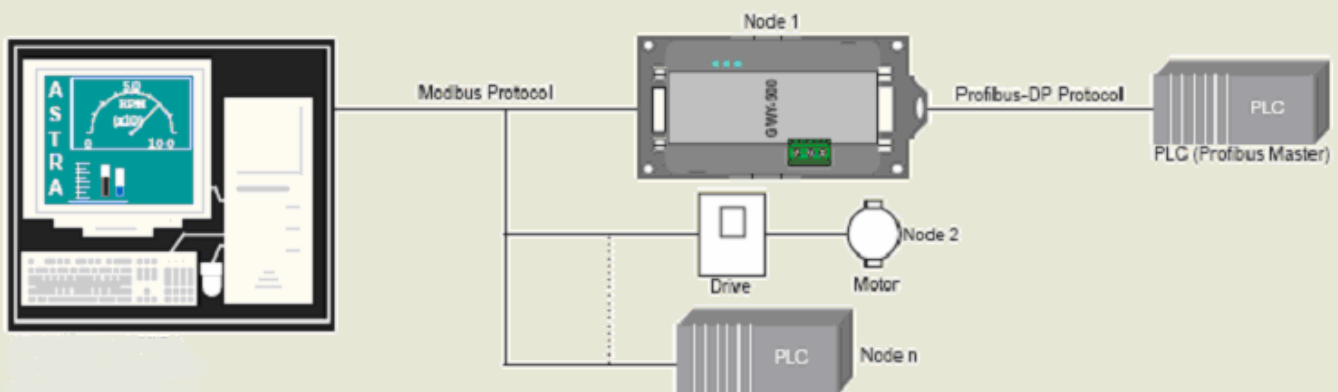

### 4. Add I/O to your PLC

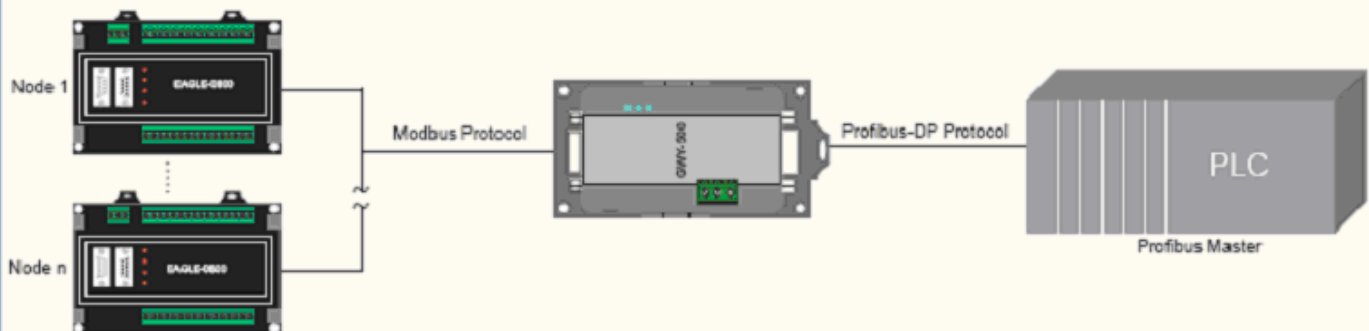

\* Images not to scale.

## Basic Gateway Operations

GWY-500 is a Protocol Converter / Data sharer for devices like PLC's, Inverters, Controllers etc. GWY-500 has a serial port, that connects to a serial device and a Profibus-DP port, that connects to Profibus network. Gateway allows serial devices to act as a slave on a Profibus network. It also allows Profibus Master PLC's to act as a serial device (e.g. Modbus Master or Modbus Slave).

Our Windows® based Gateway setup software makes it easy to configure the protocol converter. After choosing which protocol to be used for each port, you can program the Gateway to transfer the data blocks. Using a simple spreadsheet format, you can simply program the Gateway to fetch a specified number of registers or bits from one device and transfer them to the other. Powerful software allows you to have all the information transfers done continuously or allows the PLC to control which blocks of data are to be transferred.

System requirements for Gateway Setup Software are:

Windows Version	:	Microsoft Windows 9x/NT/2000/XP
Processor	:	PENTIUM or higher
Hard disk Space	:	5 MB or more
Mouse	:	Required
RAM	:	16 MB or more
Display resolution	:	800 X 600 (VGA) or better
Display colors	:	16 bit color

Other Items required for GWY-500 configuration:

1. Gateway unit
2. Gateway Configuration Cable
3. Gateway Setup Software
4. Devices with communication cables

## Communication Ports

The GWY-500 has two communication ports. Pin-out of these ports are as shown below:

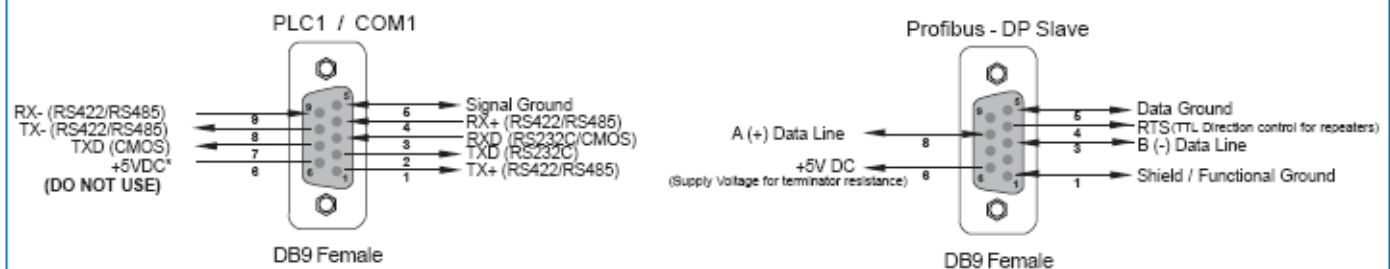

\*Do not use pin no. 6 of PLC1 / COM1.

**Data Line:** The Profibus user group recommends the following colour coding for the data signal lines:

**A-Data Line = Green**      **B-Data Line = Red**

These data signal lines must be connected to the corresponding signal terminals or pins at the master unit and other stations (i.e. A to A, B to B).

**RTS:** The signal RTS (TTL signal relative to Data Ground) is meant for the direction control of repeaters in case repeaters without self control capability are used.

**+5V DC, Data Ground:** The signals +5V DC and Data Ground are meant to power an externally mounted bus terminator.

The powering of the 220 Ω termination resistor ensures a defined idle state potential on the data lines. To ensure proper functioning up to the highest baud rate, each bus segment has to be terminated at both ends of the cable.

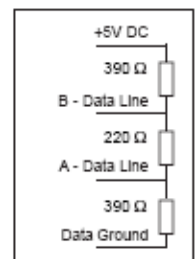

## PLC's supported

The GWY-500 currently supports Modbus RTU (Master), Modbus RTU (Slave), Toshiba T1, T2, T3 (Link Port) PLC's and Toshiba S11 Inverter protocol.

It can also support many major brand PLC protocols (e.g. Allen Bradley, Omron, GE, LG, Siemens, Schnider, etc.).

**New PLC drivers are constantly added. Please contact factory for more information. We welcome an opportunity to develop new, custom drivers and customization of Gateway products.**

## General specifications

Power	: +24V DC + 10%, 100mA max
LED's	: 3 LED's for status indication
Communication Ports	: 2 Communication ports with
COM1 (DB9 Female)	: RS232 / RS422 / RS485 / CMOS
COM2 (DB9 Female)	: Profibus - DP Slave (2 wire RS485)
Profibus Baud rate	: 9.6k, 19.2k, 45.45k, 93.75k, 187.5 k,
(Autodetect)	500k, 1.5M, 3M, 6M, 12M bit/s
GSD File	: Supplied with the unit
<i>(Isolation between communication ports and Power supply, through DC-DC coupler is 1 KV)</i>	
COM1 / PLC1	: Connects to PC for setup download or connects to PLC1 at runtime.
COM2 / PLC2	: Connects to Profibus - DP Network.
<i>(Isolation between communication ports, through opto-isolation is 1KV for 1 min)</i>	
I/O data	: 100 Word Input, 100 Word Output
BUS Address	: 0 - 255 Setting through setup software
Temperature	: Operating : 0° to 60°C Storage : -20° to 80°C
Humidity	: 10% to 90% (Non condensing)
Mounting	: DIN rail or back panel mounting
Weight	: 125 gm approx.
Certifications	: CE, CSA and UL
Immunity to ESD	: Level 3 as per IEC1000-4-2
Immunity to Transients	: Level 3 as per IEC1000-4-4
Immunity to Radiated RF	: Level 3 as per IEC1000-4-3
Immunity to Conducted RF	: Level 3 as per IEC1000-4-6
Emissions	: EN55011 CISPR A

## Models

Series/Model	Technology	Protocol
GWY-00 *	Serial	Various
GWY-100 *	LONWORK	LonTalk
GWY-200 **	CANBus	DeviceNet
GWY-300 *	CANBus	CAN (J1939-71)
GWY-400 *	USB	Various
GWY-500 **	Profibus	Profibus-DP
GWY-600 #	Ethernet	Various

\* Released

\*\* Coming soon

# Contact Factory

## Dimensions

GWY-500 units are shipped with a separate DIN rail plate which can be attached to the unit, if desired. User can use the unit with or without the DIN rail plate. Following sketch shows dimensional details of GWY-500 with the DIN rail plate.

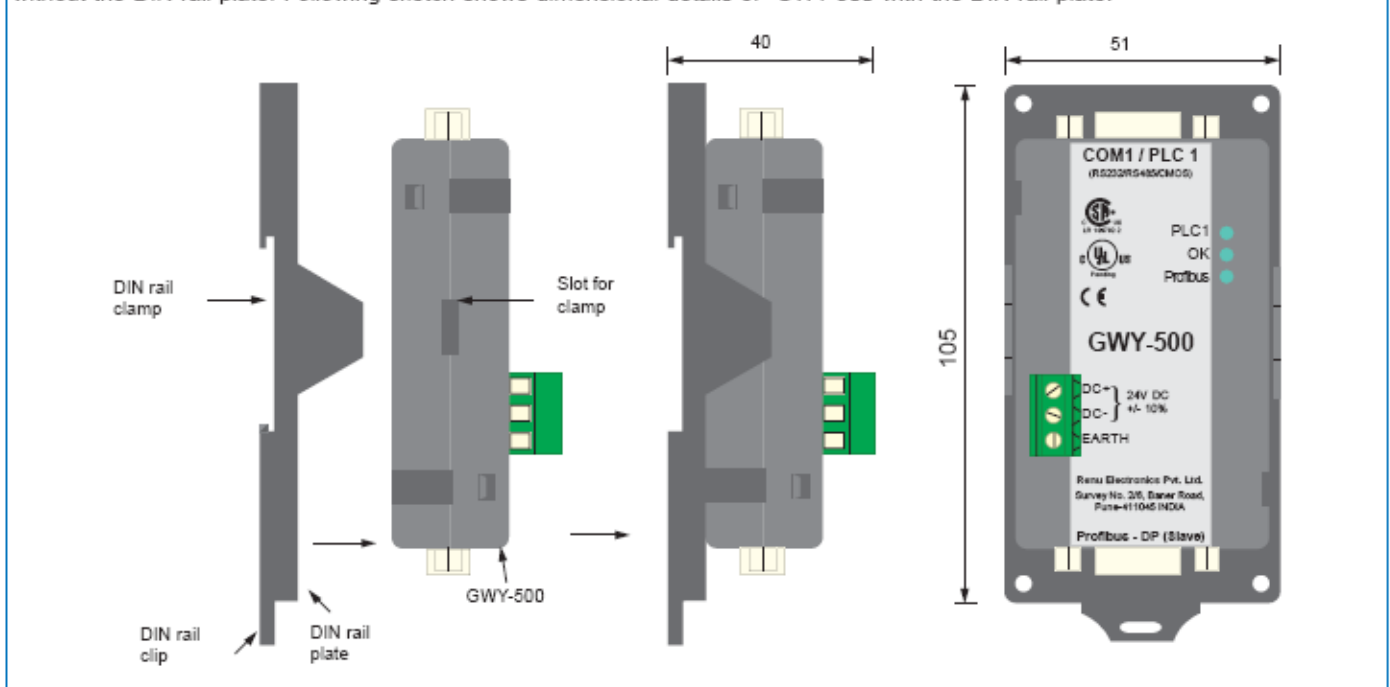

Casuarina Services Pte Ltd  
 Blk 1004 Toa Payoh North #06-08  
 Singapore 318995  
 Tel : 65-67422869 Fax : 65-64578790  
 Email : sales@casuarina.com.sg  
 www.casuarina.com.sg

