

General Information

HFV-Series

Differential Pressure Type
Venturi Cone Flowmeter



HITROL CO., LTD.



General

HFV-Series is an innovative differential-pressure flow meter which broke the conventional concept based on the fluid mechanics.

HFV-Series is a new flow meter which measures the differential pressure generated by a cone-shaped body at the center of pipe, has less pressure loss, and an excellent, highly reliable and accurate flow meter traceable to Korea National Standards.

Measurement Principle

- D : inside diameter of pipe
- β : beta ratio
- A_2 : cross sectional area at reduced area
- E : velocity-of-approach factor
- ρ : density of fluid
- d: maximum diameter of cone
- Cd: discharge coefficient
- m: effective area ratio
- ϵ : expansion coefficient
- P: differential pressure

The measurement principle of HFV-Series flow meter is that if cross sectional area of a pipe section is reduced, then the flow velocity is increased(continuity equation), pressure is decreased(Bernoulli equation), and differential pressure is generated between two locations(A-B). This generated differential pressure(P) and flow rate(Q_v) have a proportional relationship such as $Q_v \propto K \sqrt{P}$, and therefore, flow rate can be found by measuring differential pressure.

HFV-Series flow meter can generate differential pressure by reducing the cross sectional area of the pipe with a cone-shaped flow element located at the center of pipe. This is the same principle as the other differential pressure flow meters, however, it is a new configuration which the center of pipe is plugged instead. The effective area ratio(m)and beta ratio(β) are defined as follows.

$$m = \frac{D^2 - d^2}{D^2} \quad \beta = \frac{\sqrt{D^2 - d^2}}{D}$$

Therefore, equation for flow rate calculation can be given as follows.

$$Q_v = C_d \cdot A_2 \cdot E \cdot \epsilon \cdot \sqrt{\frac{2 \cdot P}{\rho}}$$

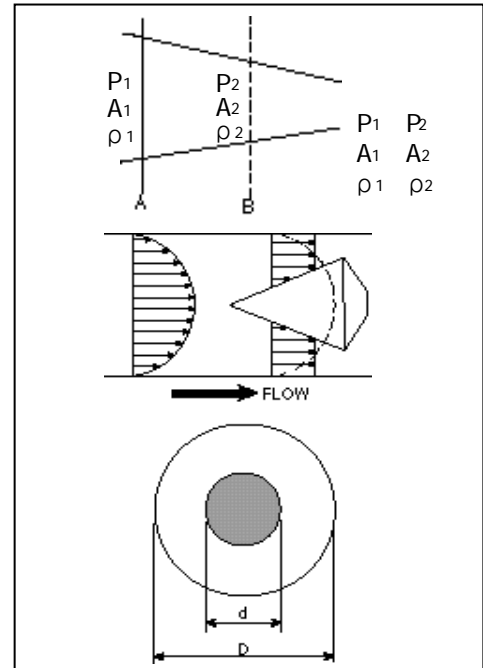

Specifications

Measuring fluid	liquid, gas, steam
Material	304 SS(custom order : 316 SS, PVC, etc.)
Pressure range	10 kgf/cm ² (custom order : over 10 kgf/cm ²)
Temperature range	Max. 350 °C
Uncertainty	± 0.5 %
Repeatability	± 0.1 %
Straight pipe section	upstream 3D, downstream 5D
Turndown ratio	10:1(custom order 30:1)

Flow Measurement System

*** Measuring the incompressible fluids**

- ① HFV-Series flow sensor
- ② 3-way or 5-way valve
- ③ Differential pressure transmitter
- ④ Flow computer or flow indicator

*** Measuring the compressible fluids**

- ① HFV-Series flow sensor
- ② 3-way or 5-way valve
- ③ Differential pressure transmitter
- ④ Flow computer or flow indicator
- ⑤ Pressure sensor
- ⑥ Temperature sensor(Pt 100Ω)

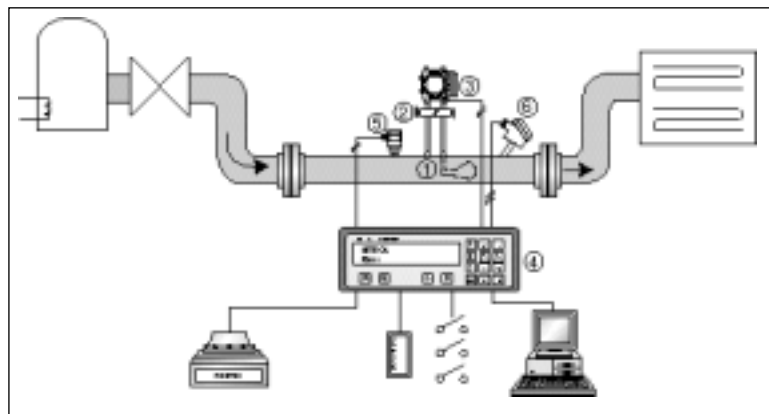

- * Excellent repeatability and high accuracy
- * Wide flow rate measurement range
- * High reliability since it has no moving parts
- * Short upstream and downstream straight pipe section
- * Every unit is tested by national flow standard system

Features

Dimension

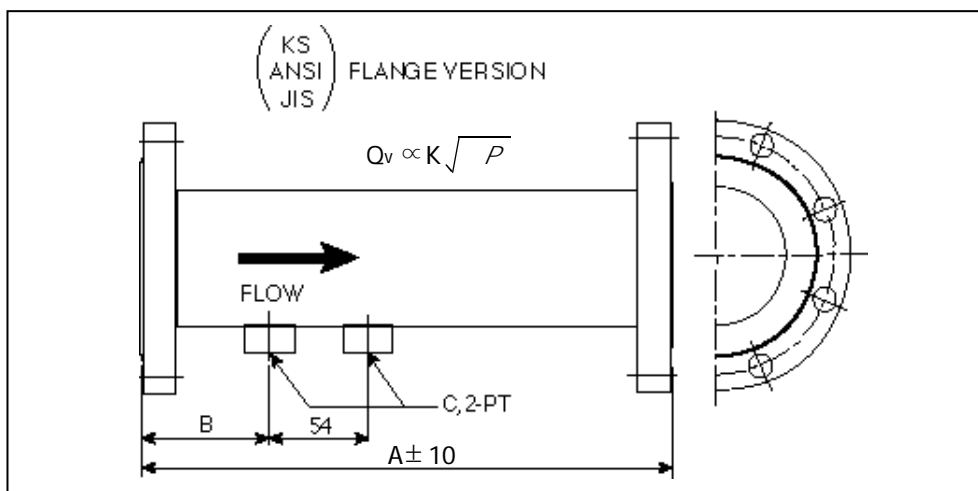

Model	Size	A(mm)	B(mm)	C(PT)
HFV-0015	15A	200	65	1/4
HFV-0020	20A	200	65	1/4
HFV-0025	25A	200	65	1/4
HFV-0040	40A	260	75	1/4
HFV-0050	50A	300	90	1/2
HFV-0065	65A	300	90	1/2
HFV-0080	80A	360	90	1/2
HFV-0100	100A	400	100	1/2
HFV-0125	125A	560	110	1/2
HFV-0150	150A	560	110	1/2
HFV-0200	200A	660	130	1/2
HFV-0250	250A	710	130	1/2
HFV-0300	300A	760	130	1/2
HFV-0350	350A	760	150	1/2
HFV-0400	400A	760	150	1/2
HFV-0450	450A	920	150	1/2
HFV-0500	500A	920	150	1/2
HFV-0600	600A	1220	150	1/2
HFV-0700	700A	1220	150	1/2
HFV-0750	750A	1525	150	1/2
HFV-0800	800A	1525	150	1/2
HFV-0900	900A	1525	150	1/2
HFV-1000	1000A	2030	150	1/2
HFV-1200	1200A	2030	150	1/2
HFV-1500	1500A	2540	150	1/2
HFV-2000	2000A	3050	150	1/2

Table 1. Measurement range of liquid flowrate

Model	Differential Pressure	Max. flowrate (m ³ /h)				
	(mm H ₂ O)	$\beta=0.4$	$\beta=0.5$	$\beta=0.6$	$\beta=0.7$	$\beta=0.8$
HFV-0015	250	0.241	0.384	0.573	0.835	1.237
	5000	1.077	1.715	2.564	3.734	5.533
HFV-0020	250	0.426	0.678	1.013	1.476	2.187
	5000	1.903	3.031	4.530	6.599	9.778
HFV-0025	250	0.677	1.087	1.611	2.347	3.478
	5000	3.027	4.822	7.206	10.498	15.555
HFV-0040	250	1.567	2.496	3.730	5.434	8.051
	5000	7.007	11.162	16.681	24.299	36.007
HFV-0050	250	2.471	3.936	5.883	8.570	12.699
	5000	11.051	17.604	26.309	38.325	56.790
HFV-0065	250	4.146	6.605	9.871	14.279	21.307
	5000	18.543	29.538	44.144	64.305	95.286
HFV-0080	250	5.679	9.046	13.518	19.639	29.180
	5000	25.395	40.453	60.456	88.068	130.499
HFV-0100	250	9.756	15.540	23.225	33.832	50.132
	5000	43.629	69.499	103.865	151.301	224.198
HFV-0150	250	20.796	33.127	49.507	72.118	106.864
	5000	93.002	148.148	221.403	322.522	477.912
HFV-0200	250	35.684	56.842	84.949	123.747	183.368
	5000	159.582	254.207	379.905	553.414	820.048
HFV-0250	250	55.876	89.008	133.021	193.774	287.133
	5000	249.887	398.058	594.888	866.582	1284.100
HFV-0300	250	80.578	128.357	191.826	279.436	414.068
	5000	360.356	574.030	857.873	1249.678	1851.770
HFV-0350	250	99.688	158.798	237.319	345.706	512.267
	5000	445.816	710.164	1061.323	1546.046	2290.927
HFV-0400	250	131.722	209.827	313.581	456.799	676.884
	5000	589.079	938.375	1402.379	2042.867	3027.116
HFV-0500	250	209.159	333.181	497.931	725.344	1074.813
	5000	935.389	1490.031	2226.814	3243.836	4806.708
HFV-0600	250	310.811	495.108	739.926	1077.862	1597.173
	5000	1389.990	2214.189	3309.050	4820.345	7142.776
HFV-0700	250	423.049	673.897	1007.122	1467.090	2173.930
	5000	1891.931	3013.757	4503.985	6561.025	9722.112
HFV-0750	250	485.642	773.606	1156.134	1684.159	2495.583
	5000	2171.859	3459.670	5170.390	7531.789	11160.588
HFV-0800	250	552.553	880.191	1315.424	1916.199	2839.419
	5000	2471.093	3936.335	5882.755	8569.502	12698.269
HFV-0900	250	699.325	1113.992	1664.834	2425.189	3593.640
	5000	3127.477	4981.925	7445.362	10845.776	16071.247

※ Standard condition : 1 ATM. at 20 °C

Table 2. Measurement range of gas flowrate

Model	Line Pressure (kg/cm ²)	Differential Pressure (mm H ₂ O)	Multi Flowrate (dm ³ /s)	Max. flowrate (m ³ /h)				
				β=0.4	β=0.5	β=0.6	β=0.7	β=0.8
HFV-0015	0	100	2.00	3.68	5.84	8.68	12.51	18.09
	10	1250	18.00	35.32	56.08	83.26	119.72	172.49
	20	3000	38.00	81.94	130.00	192.72	276.26	395.48
HFV-0020	0	100	2.67	6.50	10.32	15.34	22.10	31.96
	10	1250	24.00	62.41	99.09	147.13	211.57	304.82
	20	3000	50.67	144.80	229.73	340.56	488.20	698.88
HFV-0025	0	100	3.36	10.34	16.42	24.41	35.16	50.84
	10	1250	30.25	99.28	157.64	234.06	336.56	484.89
	20	3000	63.86	230.34	365.45	541.75	776.62	1111.76
HFV-0040	0	100	5.11	23.93	38.01	56.49	81.38	117.69
	10	1250	46.00	229.80	364.88	541.78	779.06	1122.41
	20	3000	97.11	533.18	845.92	1254.02	1797.67	2573.44
HFV-0050	0	100	6.42	37.74	59.95	89.10	128.35	185.62
	10	1250	57.75	362.44	575.50	854.50	1228.74	1770.27
	20	3000	121.92	840.94	1334.20	1977.85	2385.29	4058.84
HFV-0065	0	100	8.33	63.33	100.60	149.50	215.36	311.44
	10	1250	75.00	608.14	965.61	1433.73	2061.66	2970.28
	20	3000	158.33	1410.99	2238.61	3318.58	4757.25	6810.22
HFV-0080	0	100	9.72	86.73	137.77	204.75	294.95	426.53
	10	1250	87.50	832.87	1322.45	1963.56	2823.53	4067.93
	20	3000	184.72	1932.41	3065.87	4544.93	6515.26	9326.88
HFV-0100	0	100	12.75	149.00	236.69	351.76	506.72	732.78
	10	1250	114.75	1430.87	2271.97	3373.41	4850.85	6988.72
	20	3000	242.25	3319.89	5267.18	7808.22	11193.26	16032.64
HFV-0150	0	100	18.61	317.61	504.54	749.82	1080.15	1562.04
	10	1250	167.50	3050.12	4843.06	7109.94	10340.33	14897.55
	20	3000	353.61	7076.85	11227.82	16644.44	23860.16	34156.88
HFV-0200	0	100	24.36	544.99	865.74	1286.62	1853.43	2680.29
	10	1250	219.25	5233.70	8310.20	12338.91	17742.95	25562.66
	20	3000	462.86	12143.15	19265.79	28560.15	40941.58	58609.70
HFV-0250	0	100	30.56	853.39	1355.65	2014.70	2902.25	4197.03
	10	1250	275.00	8195.37	13012.81	19321.29	27783.40	40028.15
	20	3000	580.56	19014.76	30167.98	44721.87	64109.75	91775.96
HFV-0300	0	100	54.92	1230.65	1954.95	2905.35	4185.27	6052.43
	10	1250	494.25	11818.34	18765.46	27862.78	40065.78	57723.64
	20	3000	1043.42	27420.73	43504.52	64492.34	92451.15	132347.93
HFV-0350	0	100	61.11	1522.51	2418.58	3594.36	5177.83	7487.80
	10	1250	550.00	14621.13	23215.79	34470.59	49567.60	71413.13
	20	3000	1161.11	33923.72	53821.86	79787.06	114376.46	163734.99
HFV-0400	0	100	93.61	2011.77	3195.79	4749.41	6841.72	9894.00
	10	1250	842.50	19319.62	30676.17	45547.70	65496.13	94361.71
	20	3000	1778.61	44825.09	71117.50	105426.60	151131.28	216351.15
HFV-0500	0	100	176.94	3194.45	5074.54	7541.51	10863.86	15710.52
	10	1250	1592.50	30677.32	48710.20	72324.46	104000.25	149835.43
	20	3000	3361.94	71177.03	112926.32	167405.20	239978.93	343540.51
HFV-0600	0	100	215.56	4746.96	7540.78	11206.70	16143.71	23345.86
	10	1250	1940.00	45586.55	72383.44	107474.27	154544.53	222655.70
	20	3000	4095.56	105769.19	167808.70	248764.40	356609.07	510501.75
HFV-0700	0	100	333.33	6461.14	10263.84	15253.57	21973.38	31776.31
	10	1250	3000.00	62048.36	98521.90	146284.42	210352.28	303059.14
	20	3000	6333.33	143963.61	228406.29	338595.99	485384.57	694849.61
HFV-0750	0	100	361.11	7417.12	11782.47	17510.47	25224.55	36477.91
	10	1250	3250.00	71228.98	113099.12	167928.54	241475.83	347899.52
	20	3000	6861.11	165264.35	262201.10	388694.37	557201.67	797658.99
HFV-0800	0	100	388.89	8439.04	13405.83	19923.02	28699.93	41503.75
	10	1250	3500.00	81042.75	12861.67	191065.36	274745.84	395832.35
	20	3000	7388.89	188034.11	298326.58	442247.82	633971.68	907558.67
HFV-0900	0	100	430.56	10680.66	16966.75	25215.08	37.39.45	52528.18
	10	1250	3875.00	102569.73	162862.74	241817.10	355701.53	500975.31
	20	3000	8180.56	237980.67	377569.58	559719.90	825293.06	1148628.95

※ Standard condition : 1 ATM. at 20 °C

Installation Method

HFV-series flow meter can be installed horizontally or vertically, it is determined according to status of measuring fluid, properties of fluid(gas, steam, liquid, viscosity, etc.) and location of

measurement made.

Customers should be familiar with installation method of HFV-series flow meter, and refer to ISO 5167, or contact to HITROL Co., Ltd. if there should be questions.

Installation-1. Liquid flow measurement(clean liquids)

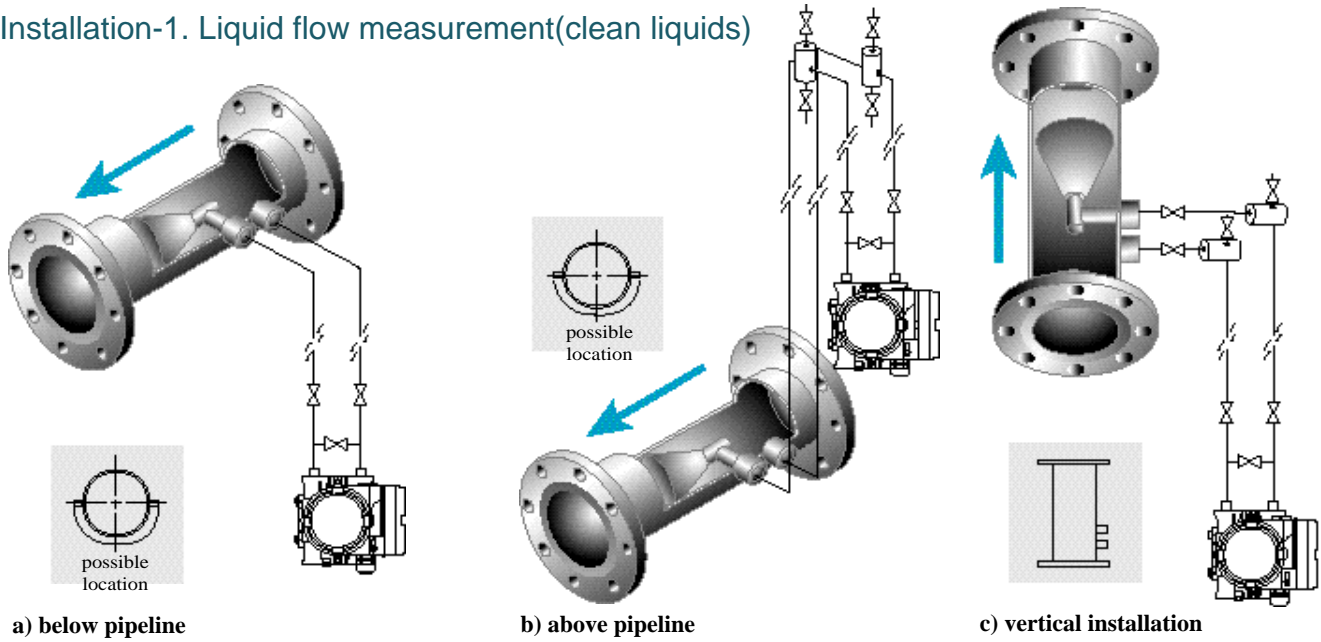

Installation-2. Gas flow measurement(clean noncondensable gas)

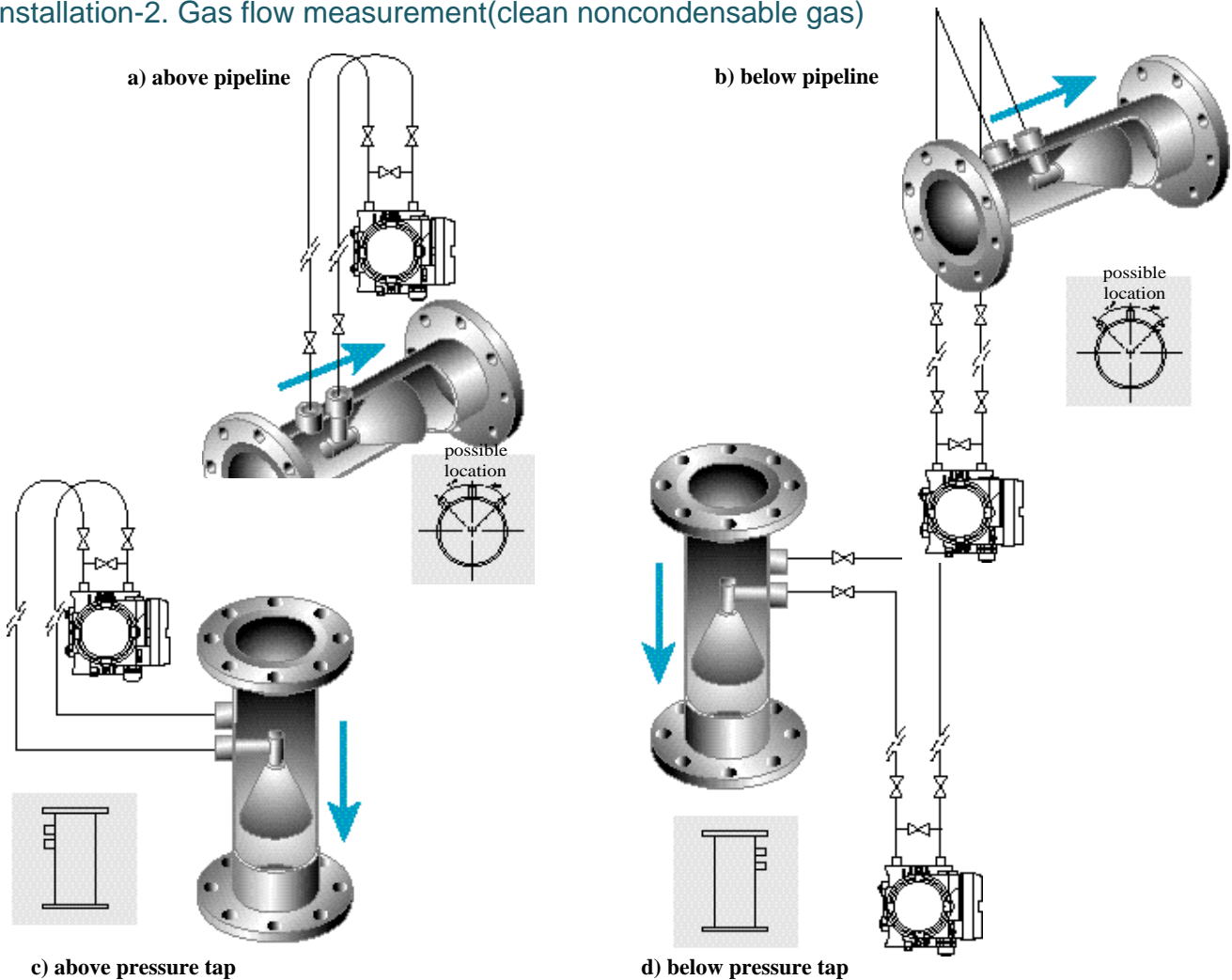

Installation-3. Steam(saturated, superheated) flow measurement

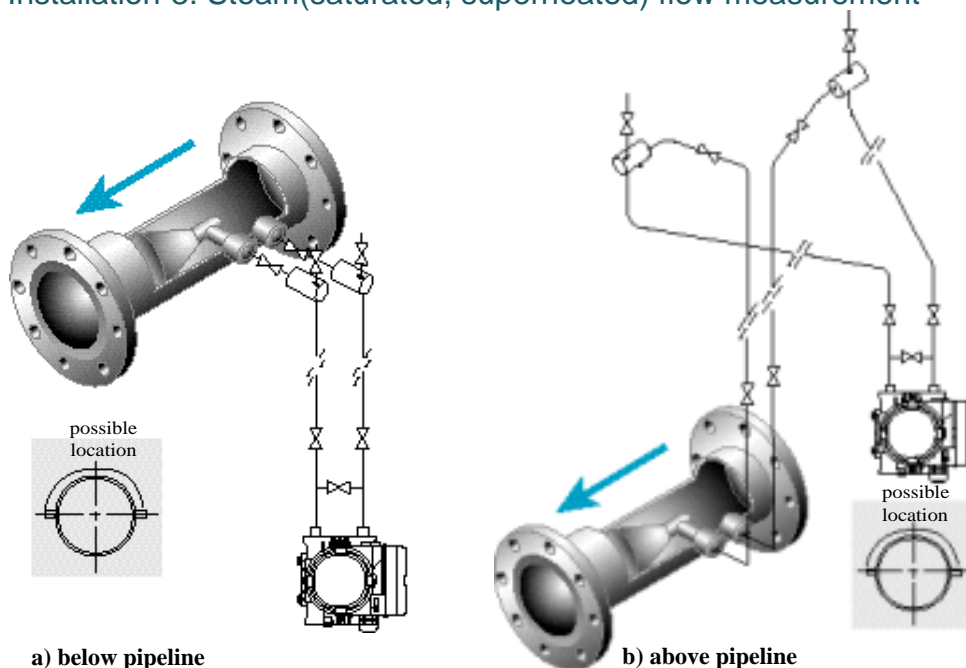

Differential pressure taps should be located upper side of pipeline between 45° from vertical line for gases, lower

side of pipeline between 45° from vertical line, and side of pipeline for steam(See figure below).

Differential Pressure Taps

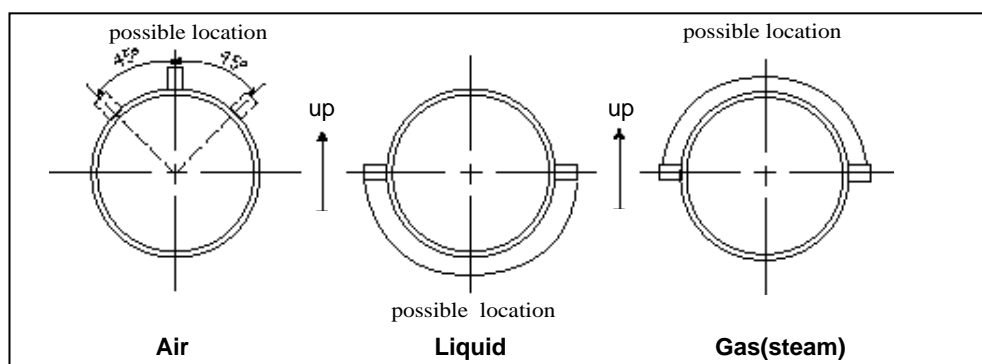

Pressure measuring tubes should have a gradient over 1/10 for any case so that any undesirable gases or drainages should not be transferred to differential pressure transmitter. For horizontal pressure measuring tube, gas or drainage separator should be installed. Pressure measuring tubes should not have abrupt bendings.

For the case that the pressure measuring tubes are long, it should be installed using mounting brackets.

Pressure Measuring Tube

There should be no excessive pressure or force when assembling the pressure measuring tubes and differential pressure transmitter.

High temperature measuring tubes should be used when pressure measuring tube are likely exposed to high temperature problems.

Pressure measuring tubes should be basically installed to connect the equalizing valve to the connection port of differential pressure transmitter CPT 1/4 " female thread).

Process pipe line should be connected to

PT 1/2 " tubing is used instead of equalizing valve, oval flanges should be used.

High pressure tap should be connected to (+), and low pressure tap should be connected to (-) of differential pressure transmitter.

Connection of Pressure Measuring Tubes and differential Pressure Transmitter

VENTURI CONE FLOW SENSOR (HFV-Series)

- * Type : Venturi Cone
- * Installation : Local Mounting
- * Mounting Method : Flange
- * Repeatability : $\pm 0.1\%$
- * Accuracy : $\pm 0.5\%$ F. S
- * Turn Down Ratio : 10:1
- * Normal Pressure : Max. 10 kgf/cm²
- * Temperature : Max. 350 °C

ORDER CODES

MODEL : HFV-Series (Material STS 304 / Pressure 10 kg/cm²기준)

- * Wet Part Cone & Body Material
S1 : 304 SS
S2 : STS SS
- * Pressure
A : 10 kgf/cm²
B : 20 kgf/cm² (OPTION)
- * Model No. & Line Size / Tap Size

1 : HFV-0015	15 mm / 1/4 "
2 : HFV-0020	20 mm / 1/4 "
3 : HFV-0025	25 mm / 1/4 "
4 : HFV-0040	40 mm / 1/4 "
5 : HFV-0050	50 mm / 1/4 "
6 : HFV-0065	65 mm / 1/2 "
7 : HFV-0080	80 mm / 1/2 "
8 : HFV-0100	100 mm / 1/2 "
9 : HFV-0150	150 mm / 1/2 "
10 : HFV-0200	200 mm / 1/2 "
11 : HFV-0250	250 mm / 1/2 "
12 : HFV-0300	300 mm / 1/2 "
13 : HFV-0400	400 mm / 1/2 "
14 : HFV-0500	500 mm / 1/2 "
15 : HFV-0600	600 mm / 1/2 "
16 : HFV-0700	700 mm / 1/2 "
17 : HFV-0800	800 mm / 1/2 "
- * Others
D : Differential Pressure Transmitter
P : Pressure Transmitter
T : Temp. Sensor(pt 100 Ω)
3 : 3-way Valve.
F : Flow Computer

HFV - 吩 吩 吩 吩

SYSTEM ARRANGEMENT

- 1) Liquid Flow
Sensor = HFV-1000 / HFV-2000
Manifold = 3-Way V/V & 5-Way V/V
Differential Pressure Transmitter
Flow Computer & Display For Flowrate
- 2) Mass Flowrate (Gas, Steam, Liquid) :
Sensor = HFV-1000 / HFV-2000
Manifold = 3-Way V/V & 5-Way V/V
Differential Pressure Transmitter
Flow Computer & Display For Flowrate
Pressure Sensor
Temperature Sensor



HITROL CO., LTD.

HEAD OFFICE · FACTORY · R & D INSTITUTE
62-182 BONGILCHEON-RI CHORI-MYUN
PAJU CITY KYUNGGI-DO KOREA
TEL : (031) 943-0875~7
FAX : (031) 943-0878, 5600
<http://www.hitrol.co.kr> hitrol@hitrol.co.kr