

FOX FT2

Model FT2 Gas Mass Flowmeter & Temperature Transmitter

- X Measures gas flow rate in SCFM, NM³/Hr, Kg/Hr, & many more
- X Measures process gas temperature
- X Outputs: 2 x 4 to 20 mA - one for flow rate and one for temperature; pulse output for flow/total
- X RS232 for connecting a Palm Handheld or computer; RS422/RS485-Modbus, Profibus-DP, DeviceNet & Ethernet
- X Insertion and in-line models
- X All welded, 316 SS sensor construction; Hastelloy C276 optional
- X Microprocessor based, field programmable
- X On-board 2 x 16 character, backlit display with configuration panel to view/set readings and parameters
- X Palm handheld terminal available to view/set readings and parameters when on-board display & configuration panel is not ordered
- X NEMA 4X enclosure; designed for Class I, Division 2, Groups B, C, & D hazardous areas
- X NIST traceable calibration; CE approved
- X Low-end sensitivity – leak detection
- X Negligible pressure drop
- X No moving parts



PRODUCT DESCRIPTION

The Fox Model FT2 Thermal Mass Flowmeter and Temperature Transmitter measures two important process variables in one rugged instrument. The FT2 measures gas flow rate in standard units without the need for temperature or pressure compensation. It provides isolated 4 to 20 mA and pulse outputs for flow rate and a 4 to 20 mA output for process gas temperature. The pulse output is normally used for totalization. You choose the flow rate and temperature engineering units. An optional on-board 2 x 16 characters, backlit display is available to view flow rate, total, elapse time, process gas temperature, and alarms. The display is also used in conjunction with the Configuration Panel to configure flowmeter settings such as 4 mA and 20 mA for flow rate and temperature, pulse output frequency scaling, pipe area, zero flow cutoff, flow filtering (dampening), display configurations, diagnostics and high or low alarm limits. It also permits review of certain raw flowmeter data which is useful when troubleshooting. If you prefer, you can view measurements and set parameters with an optional Fox Handheld Palm Terminal instead of the on-board Display and Configuration Panel.

FT2 is available in insertion and in-line models. The insertion meter is easily installed by drilling a 3/4" hole in the pipe and welding on a 3/4" NPT coupling. A Fox supplied compressing fitting secures the probe in place. The in-line model is available in 1/4-inch to 6-inch sizes and include built in flow conditioners that eliminate the need for long, straight pipe runs. The meter can be ordered with flange or NPT end connections. Both models are supplied with 316 stainless steel wetted materials standard or Hastelloy C-276 as an option.

RS232 for connecting a Palm Handheld or computer; RS422/RS485-Modbus, Profibus-DP, DeviceNet and Ethernet give the FT2 flexible communications capability. The FT2 is an advanced Thermal Mass Flowmeter and Temperature Transmitter for your most challenging gas flow measurement applications.

SPECIFICATIONS

Performance Specs

Flow Accuracy:

± 1% of reading ± 0.2 % of full scale*

* Point velocity for insertion flowmeters. Fox recommends a minimum of 15 diameters of straight pipe upstream of the flowmeter and 10 diameters downstream for insertion flowmeters. Fox recommends a minimum of 8 diameters of straight pipe upstream of the flowmeter and 4 diameters downstream for inline flowmeters.

Flow Repeatability:

± 0.2% of full scale

Flow Response Time:

0.9 seconds (one time constant)

Temperature Accuracy:

± 1.8° F (± 1.0° C) over -40 to 300° F (-40 to 149° C); ± 3.6° F (± 2.0° C) over 300 to 500° F (149 to 260° C). Minimum velocity 60 SFPM.

Operating Specs

Units of Measurement:

SCFM, SCFH, NM3H, NM3M, KG/HR, KG/M, KG/S, LBS/H, LBS/M, LBS/S, NLPH, NLPM

Flow Rates for Insertion Flowmeter:

0 to 32,000 sfpm (163 nmpps) - Air at 70F & 1 ATM

To determine if an Insertion Flowmeter will operate properly, divide the maximum flow rate by the pipe area. The application is acceptable if the velocity is within the velocity range above. Here are flow rates for common pipe sizes

Pipe size	scfm	nm ³ /hr
1-1/2" (40mm)	0-450	0-760
2" (50mm)	0-750	0-1280
3" (80mm)	0-1600	0-2720
6" (150mm)	0-6400	0-10870
8" (200mm)	0-11100	0-18860
10" (250mm)	0-18200	0-30920
12" (300mm)	0-24900	0-42300

Use the equation above for larger pipe sizes.

Full Scale Flow Ranges for In-Line Flowmeters:

Size	scfm range		nm ³ /hr range	
	Min	max	Min	Max
0.25"	0-0.22	0-16	0-0.37	0-27
0.5"	0-2.1	0-48	0-3.6	0-82
.75"	0-3.7	0-120	0-6.3	0-204
1"	0-6	0-192	0-10	0-326
1.5"	0-15	0-450	0-25	0-760
2"	0-23	0-750	0-39	0-1280
2.5"	0-35	0-1090	0-59	0-1855
3"	0-50	0-1600	0-85	0-2720

4"	0-90	0-2880	0-153	0-4893
6"	0-200	0-6400	0-340	0-10870

Note: Standard conditions of air at 70°F and one atmosphere. Consult factory for other gases and for flow ranges above and below those listed above.

To determine the minimum measurable flow rate for each size flowmeter divide the min range by 15. For example, the min range for the 1.5" flowmeter is 15 SCFM. Dividing by 15 results in a minimum measurable flow rate of 1 SCFM.

Gas Pressure (maximum):

Insertion Flowmeter:

500 psig (34.5 barg)

In-Line, NPT:

500 psig (34.5 barg)

Check with factory for higher pressure options

Note: Pressure ratings stated for temperature of 100°F (38°C).

Temperature:

Std sensor: -40 to 250°F (-40 to 121°C)

HT Sensor: 32 to 650°F (0 to 343°C)*

Enclosure: -40 to 158°F (-40 to 70°C) without display, 32 to 140°F, (0 to 60°C) with display

Input Power:

24 VDC, ± 10%, 0.75 amp standard; 85 to 250VAC

50/60Hz, 20 watts optional

Output:

2 x isolated 4 to 20 mA outputs (1 for flow & 1 for temperature); isolated pulse output 0 to 100Hz, 10 volts p/p for flow (the pulse output can be used as an isolated contact output for alarms)

RS232 for connecting a Palm Handheld or computer; RS422/RS485-Modbus, Profibus-DP, DeviceNet & Ethernet

Physical Specs

Sensor material:

316 stainless steel standard; Hastelloy C276 optional

Enclosure:

NEMA 4X, designed for Class I, Division 2, Groups B, C & D hazardous areas. CE approved.

Cabling:

To Fox remote enclosure: 5 conductor, 22 AWG, shielded, 50 feet maximum

To remote PD696 rate/totalizer display: 2 conductor, shielded, 22 AWG, 3000 feet maximum

Retractor assemblies:

Packing gland assembly: 60 psig maximum – see figure 6

High pressure (crank) retractor: NPT 600 psig, ANSI 150 & ANSI 300 - see figure 7

Dimensional

Insertion Flowmeters:

Probe diameter: 1/2"

Equation for selecting Insertion Flowmeter probe length:
 Probe length = ½ pipe ID (in inches) + 2" + thickness of insulation (if any) + dimension of retractor (if supplied).
 Round up to the next standard probe length available.

Assuming there is no insulation or retractor, Fox recommends the following probe lengths:

Pipe Size	Probe Length
1-1/2" (40mm) to 3" (100mm)	4-inch
4" (150mm) to 8" (200mm)	6-inch
10" (250mm) to 14" (350mm)	9-inch
16" (400mm) to 20" (500mm)	12-inch
Use the equation above for larger pipe sizes	

Probe Lengths (LL) – see figure 1 = 4.0(10.2), 6.0(15.2), 9.0(22.9), 12.0(30.5), 15.0 (38.1), 18.0(45.7), 24.0(61.0), 30.0(76.2), 36.0(91.4)

Inline Flowmeter Dimensions – see figures 2, 3 & 5			
Pipe size	L	H	HH
0.25"	7.90 (20.0)	12.5 (31.8)	11.8 (30.0)
0.5"	12.0 (30.5)	12.5 (31.8)	11.8 (30.0)
0.75"	12.0 (30.5)	12.5 (31.8)	11.8 (30.0)
1"	15.0 (38.1)	12.5 (31.8)	11.8 (30.0)
1.5"	12.0 (30.5)	12.5 (31.8)	11.8 (30.0)
2"	12.0 (30.5)	12.5 (31.8)	11.8 (30.0)
2.5"	18.0 (45.7)	12.5 (31.8)	11.8 (30.0)
3"	18.0 (45.7)	12.5 (31.8)	11.8 (30.0)
4"	18.0 (45.7)	14.0 (35.6)	13.3 (33.8)
6"	24.0 (61.0)	15.0 (38.1)	14.3 (36.3)

Note: Dimensions in parenthesis are centimeters. For certified drawings, consult factory.

Theory of Operation

Fox Flowmeters use a Constant Temperature Differential (ΔT) technology. The sensor has two elements. The Reference RTD measures the gas temperature. The electronics heats the Heated Element above the gas temperature. It is the job of the electronics to maintain a constant ΔT between the gas temperature and the Heated Element. As the mass flow increases, the increased numbers of gas molecules remove more heat from the Heated Element.

The electronics senses this temperature reduction and adds additional power to the heated element in order to maintain a constant ΔT . The amount of power delivered to the Heated Element is proportional to the mass flow rate. The microprocessor then linearizes this signal to deliver a linear output.

Pressure Drop Charts for Inline Flowmeters

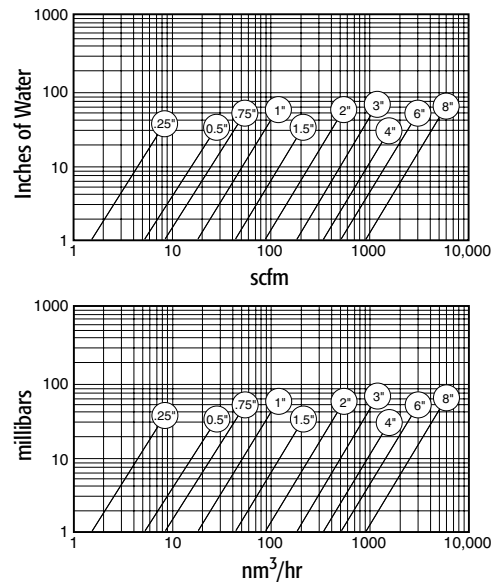

Figure 1: Insertion 4" to 36" (10.2 to 91.4 cm)

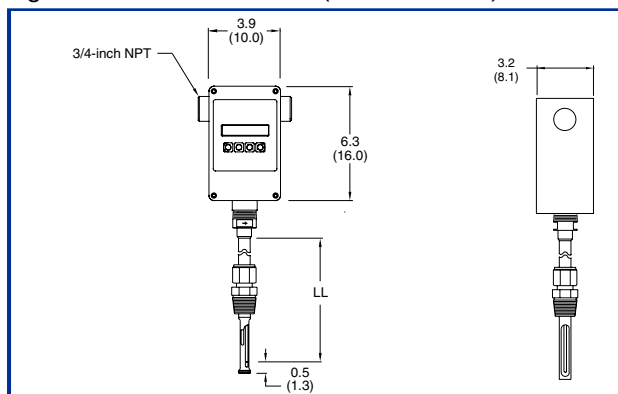
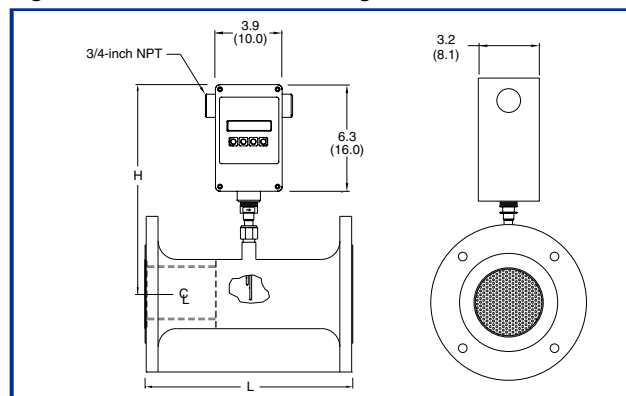

Figure 2: In-Line with 150# Flanges – sizes 0.5" to 6"



DIAGRAMS

Figure 3: In-Line with NPT Fittings – sizes 0.25" to 6"

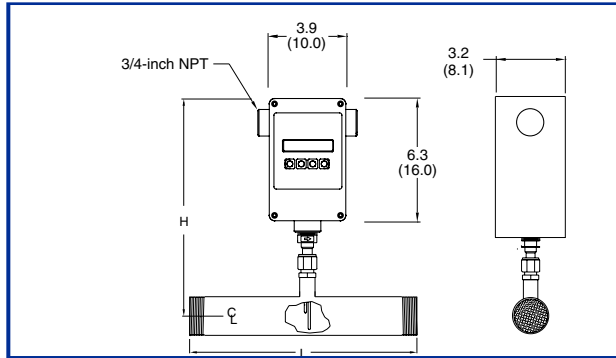

Figure 4: PD693 Rate/Totalizer

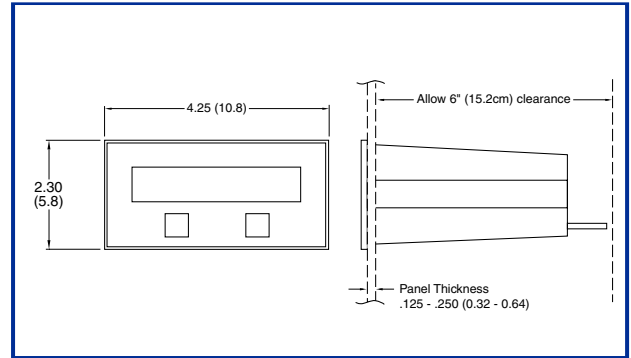

Figure 5: Remote Enclosure

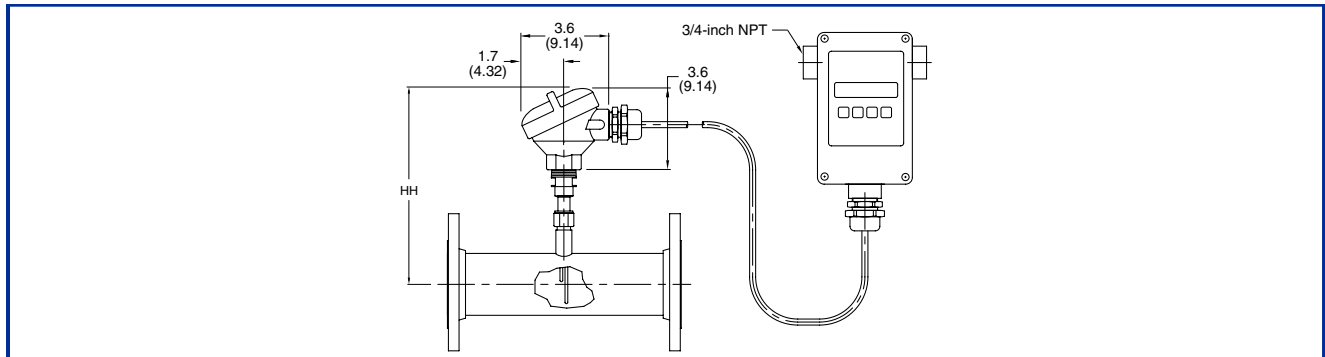

Figure 6: Packing gland assembly - 60 psig maximum

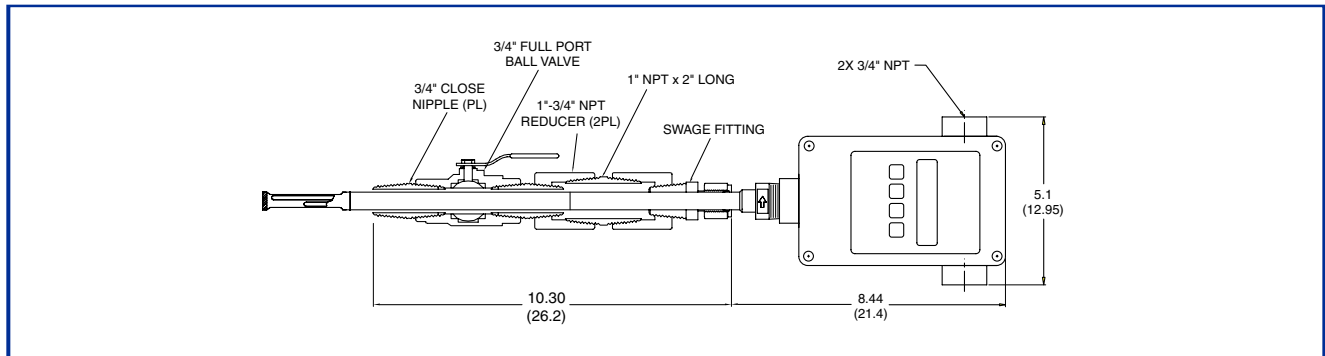
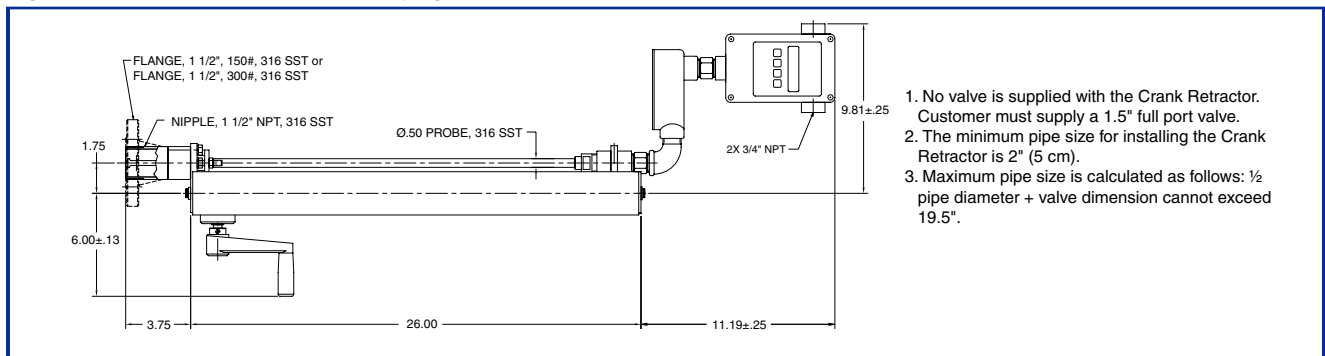

Figure 7: Crank Retractor - NPT 600 psig, ANSI 150 & ANSI 300



FOX THERMAL INSTRUMENTS, INC.
505 MAYOCK ROAD, SUITE A4 X GILROY, CA 95020 X USA
408-847-2090 X FAX: 408-847-1806
E-MAIL: sales@foxthermalinstruments.com
www.foxthermalinstruments.com