

Electropneumatic positioners

SIPART PS2

Technical description

Overview



SIPART PS2 electropneumatic positioner



SIPART PS2 EEx d electropneumatic positioner in flameproof casing



SIPART PS2 in stainless steel casing

The SIPART PS2 electropneumatic positioner is used to control the final control element of pneumatic linear or part-turn actuators. The electropneumatic positioner moves the actuator to a valve position corresponding to the setpoint. Additional function inputs can be used to block the valve or to set a safety position. A binary input is present as standard in the basic device for this purpose.

Benefits

SIPART PS2 positioners offer decisive advantages:

- Simple installation and automatic commissioning (self-adjustment of zero and span)
- Simple operation with
 - Local operation and configuration of the device using three input keys and a user-friendly two-line LCD
 - Programming through SIMATIC PDM
- Very high-quality control thanks to an online adaptation procedure
- Negligible air consumption in stationary operation
- "Tight shut-off" function (ensures maximum positioning pressure on the valve seat)
- Numerous functions can be activated by simple configuring (e.g. characteristics and limits)
- Extensive diagnosis functions for valve and actuator
- Only one device version for linear and part-turn actuators
- Few moving parts, hence insensitive to vibrations
- External non-contacting position sensor as option for extreme ambient conditions
- "Intelligent solenoid valve": Partial Stroke Test and solenoid valve function in a single device
- Partial Stroke Test e.g. for safety valves
- SIL (Safety Integrity Level) 2
- Can also be operated with natural gas

Application

The SIPART PS2 positioner is used, for example, in the following industries:

- Chemical/petrochemical
- Power stations
- Paper and glass
- Water, waste water
- Food and pharmaceuticals
- Offshore plants

The SIPART PS2 positioner is available:

- For single-action actuators: in plastic, stainless steel or aluminum casings, as well as flameproof aluminium casing (EEx d)
- For double-action actuators: in plastic and stainless steel casing, as well as flameproof aluminum casing (EEx d)
- For non-hazardous applications
- For hazardous applications in the designs
 - as intrinsically-safe device (EEx ia/ib) or
 - in flameproof aluminum casing (EEx d) or
 - in EEx n design (non sparking)

and in the versions:

- 0/4 to 20 mA control communication without/with communication through HART signal
- With PROFIBUS PA communication interface
- With FOUNDATION Fieldbus (FF) communications interface.

Explosion-proof versions

The basic version of the device is available in an intrinsically-safe design with degree of protection EEx ia/ib or in a design with approval for zone 2/zone 22 (dust).

Operation in zone 1 is permitted when enclosed in the flameproof casing version SIPART PS2 EEx d. (see "Technical Data"). It is then permissible to use all option modules (except external actuator travel detection systems, SIA module, limit value contact module and NCS).

Electropneumatic positioners

SIPART PS2

Technical description

Stainless steel casing for extreme ambient conditions

The SIPART PS2 is available in a stainless steel casing (without window in the lid) for use in particularly aggressive environments (e.g. offshore operation, chlorine plants etc.). The device functions are the same as those of the basic versions.

Design

The SIPART PS2 positioner is a digital field device with a highly-integrated microcontroller.

The positioner consists of the following components:

- Casing and cover
- PCB with corresponding electronics with or without communication through HART or with electronics for communication in accordance with
 - PROFIBUS PA specification, IEC 61158-2; bus-supplied device, or
 - FOUNDATION Fieldbus (FF) specification, IEC 61158-2, bus-supplied device
- Actuator travel detection system
- Terminal housing with screw terminals
- Pneumatic valve manifold with piezoelectric valve precontrol.

The valve manifold is located in the housing, the pneumatic connections for the inlet air and the positioning pressure on the right-hand side. A pressure gauge block and/or a safety solenoid valve can be connected there as options. The SIPART PS2 positioner is fitted to the linear or part-turn actuator using an appropriate mounting assembly. The circuit board container in the casing provides slots for separately ordered boards with the following functions:

I_y module:

- Position feedback as a two-wire signal 4 to 20 mA.

Alarm module (3 outputs, 1 input):

- Signaling of two limits of the travel or angle by binary signals. The two limits can be set independently as maximum or minimum values.
- Output of an alarm if the setpoint position of the final control element is not reached in automatic mode or if a device/fitting fault occurs.
- Second binary input for alarm signals of for triggering safety reactions e. g. for blocking function or safety position.

Limit signaling through slot-type initiators (SIA module)

Two limits can be signaled redundantly as NAMUR signals (EN 60947-5-6) by slot-type initiators. The module also contains an alarm output (see Alarm module).

Limit value signal via mechanical contacts (Limit value contact module)

Two limits can be signaled redundantly by switching contacts. A fault message output is also integrated in the module (see alarm module).

Valid for all modules described above:

All signals are electrically isolated from one another and from the basic unit. The outputs indicate self-signaling faults. The modules are easy to retrofit.

Separate mounting of actuator travel detection system and controller unit

The actuator travel detection system and controller unit can be connected separately for all casing versions of the SIPART PS2 (except flameproof design). Measurement of the travel or angle is carried out directly on the actuator. The controller unit can then be fitted a certain distance away, e.g. on a mounting pipe or similar, and is connected to the travel detection system by an electric cable and to the actuator by one or two pneumatic lines. Such a split design is frequently advantageous if the ambient

conditions at the fitting exceed the specified values for the positioner (e.g. strong vibrations).

The following can be used for measuring the travel or angle:

- NCS sensor
- External position detection system C73451-A430-D78
- A commercially available potentiometer (10 kΩ resistance) (e.g. for higher application temperatures or customer-specific applications)

The use of linear potentiometers is recommended for very small actuators with a short valve travel since, on the one hand, the space required by the linear potentiometer is very small and, on the other, the transmission characteristic is optimum for a small travel.

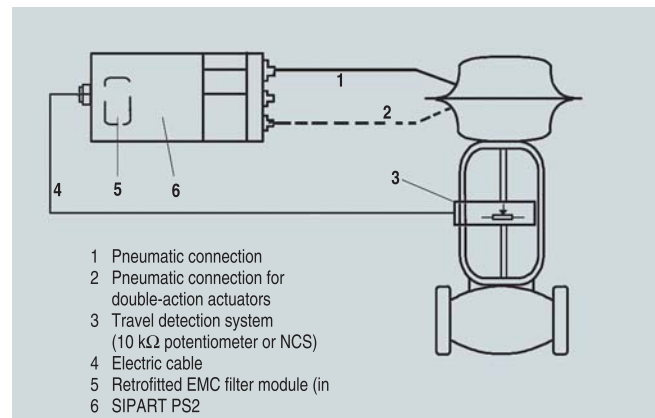

Separate connection of actuator travel detection system and controller unit

Non-contacting position sensor (NCS)



Contact and non-contacting positioning sensor (NCS) for part-turn actuator (left) and for linear actuator 14 mm (0.55 inch) (right)



NCS for travels >14 mm (0.55 inch)

The NCS sensor consists of a non-contacting position sensor. All coupling elements are omitted such as coupling wheel and driver pin with part-turn actuators or lever and pick-up bracket with linear actuators up to 14 mm travel.

This results in:

- Even greater resistance to vibration and shock
- No wear of sensor
- Problem-free mounting on very small actuators
- Negligible hysteresis with very small travels.

The sensor does not require an additional power supply, i.e. SIPART PS2 (not for EEx d version) can be operated in a 2-wire system. The NCS (Non Contacting Position Sensor) consists of a potted sensor housing which must be mounted permanently and a magnet which is mounted on the spindle of linear actuators or on the shaft butt of part-turn actuators. For the version for travels > 14 mm (0.55 inch), the magnet and the NCS are premounted on a stainless steel frame and offer the same interface mechanically as the positioner itself, i.e. they can be mounted using the standard mounting kits 6DR4004-8V, -8VK and -8VL.

The installation of a EMC filter module in the positioner (controller unit) is necessary in order to ensure a connection level with EMC according to EN 61326/A1 and NAMUR NE21 when using external sensors (see Ordering data for "EMC filter module")

Function

The SIPART PS2 electropneumatic positioner works in a completely different way to normal positioners.

Mode of operation

Comparison of the setpoint and the actual value takes place electronically in a microcontroller. If the microcontroller detects a deviation, it uses a 5-way switch procedure to control the piezoelectric valves, which regulates the flow of air into and from the chambers of the pneumatic actuator or blows it in the opposite direction.

The microcontroller then outputs an electric control command to the piezoelectric valve in accordance with the size and direction of the deviation (deviation between setpoint w and control output x). The piezoelectric valve converts the command into a pneumatic positional increment.

The positioner outputs a continuous signal in the area where there is a large control deviation (high-speed zone); in areas of moderate control deviation (slow-speed zone) it outputs a sequence of pulses. No positioning signals are output in the case of a small control deviation (adaptive or variable dead zone).

The linear or rotary motion of the actuator is detected by the mounting assembly and transferred to a high-quality potentiometer made of plastic conductive material over a shaft and a non-floating gear transmission.

The angular error of the pick-up in cases where the assembly is mounted on a linear actuator is corrected automatically.

When connected in a 2-wire system, the SIPART PS2 draws its power exclusively from the 4 to 20 mA setpoint signal. The electric power is also connected through the 2-wire bus signal with PROFIBUS operation (SIPART PS2 PA). The same applies for the FOUNDATION Fieldbus version.

Pneumatic valve manifold with piezoelectric valve precontrol

The piezoelectric valve can release very short control pulses. This helps achieve a high positioning accuracy. The pilot element is a piezoelectric bending converter which switches the pneumatic main control unit. The valve manifold is characterized by an extremely long service life.

Local operation

Local operation is performed using the built-in LCD and the three input keys. Switching between the operating levels Automatic, Manual, Configuring and Diagnosis is possible at the press of a button.

In Manual mode the drive can be adjusted over the entire range without interrupting the circuit.

Operation and monitoring with the SIMATIC PDM communications program

The SIMATIC PDM program is available for communication through the HART interface and also for the PROFIBUS PA coupling.

The SIMATIC PDM communications software permits easy remote operation and monitoring using a PC or laptop. The positioner can also be configured using this program. Parameters which provide important information for maintenance and fault diagnosis of the complete unit can also be determined using process data and comparison data.

When operating the SIPART PS2 through the HART interface, the connection is made directly to the 2-wire cable to the SIPART PS2 positioner through a HART modem that can be connected to the RS 232 or USB interface. The signals needed for communication in conformity with the HART protocol are superimposed on the current signal in accordance with the Frequency Shift Keying (FSK) method.

Automatic commissioning

With a simple configuration menu the SIPART PS2 can be quickly adapted to the fitting and adjusted by means of an automatic startup function.

During initialization, the microcontroller determines the zero point, full-scale value, the direction of action and the positioning speed of the fitting. From this data it establishes the minimum pulse time and the dead zone, thus optimizing the control.

Low air consumption

A hallmark of the SIPART PS2 is its own extremely low consumption of air. Normal air losses on conventional positioners are very costly. Thanks to the use of modern piezoelectric technology, the SIPART PS2 consumes air only when it is needed, which means that it pays for itself within a very short time

Comprehensive monitoring functions

The SIPART PS2 has various monitoring functions with which changes on the actuator and valve can be detected and signaled if applicable when a selectable limit has been exceeded. This information may be important for diagnosis of the actuator or valve. The measured values to be determined and monitored, some of whose limits can be adjusted, include:

- Travel integral
- Number of changes in direction
- Alarm counter
- Self-adjusting dead zone
- Valve end limit position (e.g. for detection of valve seat wear or deposits)
- Operating hours (also according to temperature and positioning ranges) as well as min./max. temperature
- Operating cycles of piezoelectric valves
- Valve positioning time
- Actuator leakages

Electropneumatic positioners

SIPART PS2

Technical description

Status monitoring with 3-stage alarm concept

The intelligent electropneumatic SIPART PS2 positioner is equipped with additional monitoring functions. The status indications derived from these monitoring functions signal active faults of the unit. The severity of these faults are graded using "traffic light signaling", symbolized by a wrench in the colors green, yellow and red (with SIMATIC PDM and Maintenance Station):

- Need for maintenance (green wrench)
- Urgent need for maintenance (yellow wrench)
- Imminent danger of unit failure or general failure (red wrench)

This allows users to put early measures into action in the run-up to a serious valve or actuator fault, which can prevent an imminent system shutdown. The fact that a fault indication is signaled, such as the onset of a diaphragm break in the actuator or the progressive sluggishness of a unit, enables the user to ensure system reliability at any time by means of suitable maintenance strategies.

This three-stage alarm hierarchy also allows early detection and signaling of other faults, such as the static friction of a packing box, the wearing of a valve plug/seating, or precipitations or incrustations on the fittings.

These fault indications can be output either line-conducted over the alarm outputs (see above) of the positioner (max. 3), or via communication over the HART or fieldbus interfaces. In this case, the HART, PROFIBUS and FF versions of SIPART PS2 permit a differentiation of the various fault indications, as well as a trend representation and histogram function of all key process variables with regard to the fittings.

The LCD of the device also displays the graded maintenance requirements, complete with identification of the source of the fault.

Functional safety acc. to SIL 2

The SIPART PS2 positioners are also suitable for control of fittings, which meet the special requirements of the functional safety up to SIL 2 to IEC 61508 or IEC 61511-1.

This is a single-action, venting positioner with an input of 4 to 20 mA, PROFIBUS PA and FOUNDATION Fieldbus (FF) for mounting on pneumatic actuators with spring return.

The positioner vents the valve actuator on demand or in the event of a fault and puts the valve in the preset safety position.

This positioner meets the following requirements:

- Functional safety up to SIL 2 to IEC 61508 or IEC 61511-1, from firmware version C4 or higher for safe venting
- Explosion protection for the versions 6DR5...-E...
- Electromagnetic compatibility to EN 61326/A1, Appendix A.1

SIPART PS 2 as "intelligent solenoid valve"

Open / Close valves, safety fittings in particular, are generally pneumatically controlled over a solenoid valve. If you use SIPART PS2 instead of this type of solenoid valve, the positioner performs two tasks in a single device (without extra wiring)

- Firstly, it switches the fitting off on demand by venting the actuator (functional safety acc. to SIL 2 (see above))
- Secondly, it can perform a Partial Stroke Test at regular intervals (1 - 365 days), which prevents the blocking of the fitting, e.g. due to corrosion or furring.

As in this case SIPART PS2 is constantly working in normal operation (e.g. 99 % position), it also acts as a permanent test function for the pneumatic output circuit, which is not usually possible when using a solenoid valve.

Solenoid valves on control valves can also not normally be tested during operation. They are therefore not necessary when using SIPART PS 2 with a 4-wire connection system as the venting is carried out on demand by SIPART PS2. This means that on control valves, both the control function and the shut-off function can be carried out by a single device.

Configuring

The following settings, for example, can be configured in configuring mode as required with the SIPART PS2 positioner:

- Input current range 0 to 20 mA or 4 to 20 mA
- Rising or falling characteristic at the setpoint input
- Positioning speed limit (setpoint ramp)
- Split-range operation; adjustable start-of-scale and full-scale values
- Response threshold (dead zone); self-adjusting or fixed
- Direction of action; rising or falling output pressure with rising setpoint
- Limits (start-of-scale and full-scale values) of positioning range
- Limits (alarms) of the final control element position; minimum and maximum values
- Automatic "tight shut-off" (with adjustable response threshold)
- The travel can be corrected in accordance with the valve characteristic.
- Function of binary inputs
- Function of alarm output etc.

The key aspects of configuring the different SIPART PS2 versions are largely identical.

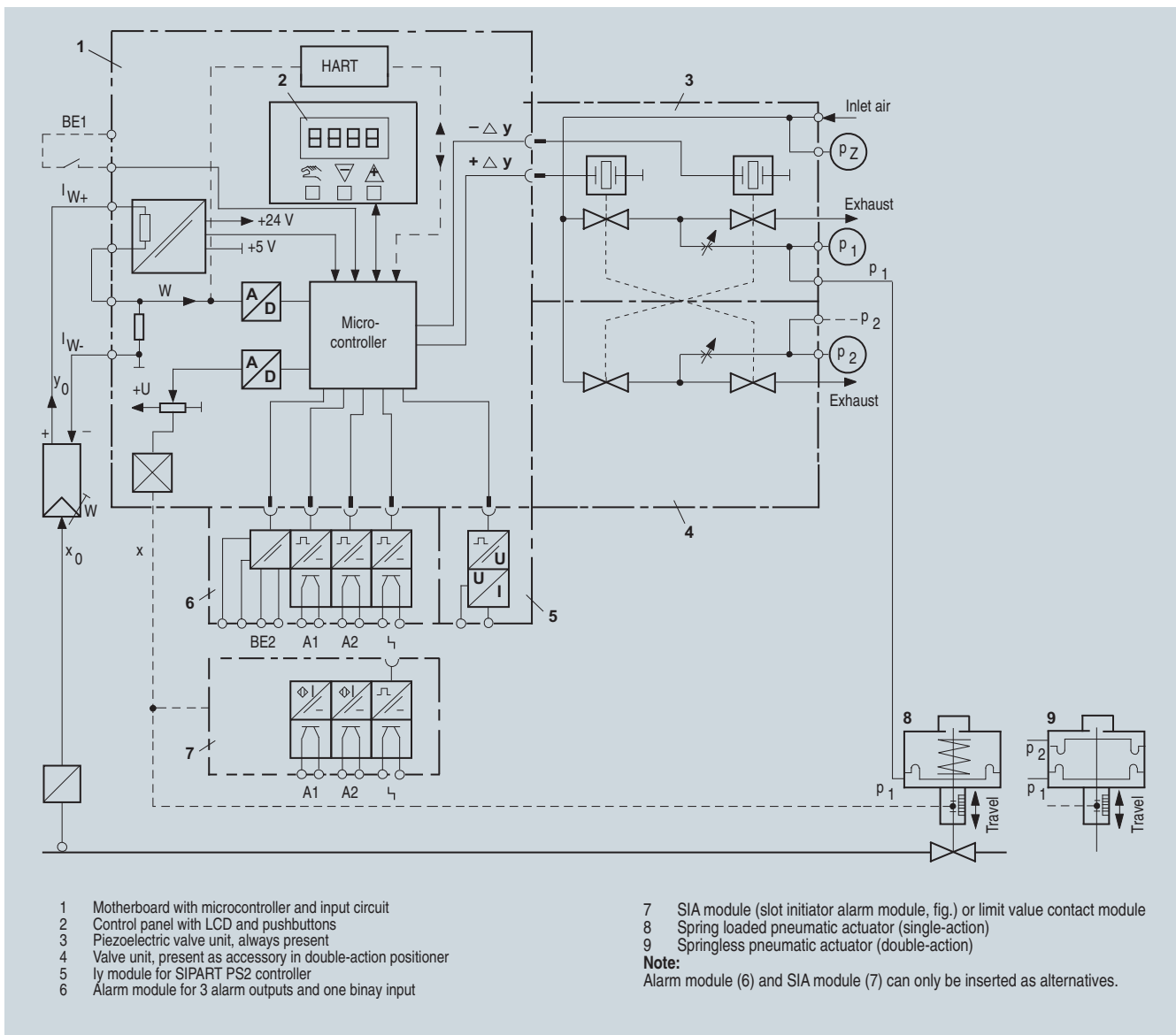

SIPART PS2, electropneumatic positioner, function diagram

Electropneumatic positioners

SIPART PS2

Technical specifications all versions

Technical specifications

SIPART PS2 (all versions)

General data

Travel range (linear actuators)	3 ... 130 mm (0.12 ... 5.12 inch) (angle of feedback shaft 16 ... 90°)
Angle of rotation (part-turn actuators)	30 ... 100°
Installation	
• On linear actuators	Using attachment set 6DR4004-8V and where necessary with an additional lever arm 6DR4004-8L on actuators according to IEC 534-6 (NAMUR) with ribs, bars or flat face
• On part-turn actuators	Using attachment set 6DR4004-8D on actuators with mounting plane according to VDI/VDE 3845 and DIN 3337: The required mounting console has to be provided on the actuator side; shaft with groove and female thread M6
Controller	
• Five-point switch	Self-adjusting
• Dead zone	
- dEbA = Auto	Self-adjusting or can be set as fixed value
- dEbA = 0.1 ... 10%	Self-adjusting or can be set as fixed value
A/D converter	
• Scan time	10 ms
• Resolution	≤ 0.05%
• Transmission error	≤ 0.2%
• Temperature effect	≤ 0.1%/10 K (≤ 0.1%/18 °F)
Cycle time	
• 20 mA/HART device	20 ms
• PA device	60 ms
• FF device	60 ms (min. loop time)
Binary input BE1 (terminals 9/10; electrically connected to the basic device)	Suitable only for floating contact; max. contact load < 5 mA with 3 V device)
Degree of protection	IP66 to EN 60 529/NEMA 4x
CE marking	Conformity as regards EMC Directive 89/336 EC in accordance with the following standards
EMC requirements	EN 61326/A1 Appendix A.1 and NAMUR NE21 August 98
Material	
• Housing	
- 6DR5..0-... (plastic)	Glass-fiber-reinforced Macrolon
- 6DR5..1-... (metal)	GD AISi12
- 6DR5..2-... (stainless steel)	Austenitic stainless steel mat. No. 1.4581
- 6DR5..5-... (metal, pressure-proof)	GK AISi12
• Pressure gauge block	Aluminium AIMgSi, anodized
Vibration resistance	
• Harmonic oscillations (sine-wave) according to DIN EN 60062-2-6/05.96	3.5 mm (0.14 inch), 2 ... 27 Hz 3 cycles/axis 98.1 m/s ² (321.84 ft/s ²), 27 ... 300 Hz, 3 cycles/axis
• Bumping (half-sine) to DIN EN 60068-2-29/03.95	150 m/s ² (492 ft/s ²), 6 ms, 1000 shocks/axis

• Noise (digitally controlled) to DIN EN 60068-2-64/08.95	10 ... 200 Hz; 1 (m/s ²) ² /Hz (3.28 (ft/s ²) ² /Hz) 200 ... 500 Hz; 0.3 (m/s ²) ² /Hz (0.98 (ft/s ²) ² /Hz) 4 hours/axis
• Recommended continuous duty range of the complete fitting	≤ 30 m/s ² (≤ 98.4 ft/s ²) without resonance sharpness
Weight, basic device	
• Plastic casing	Approx. 0.9 kg (1.98 lb)
• Metal casing, aluminium	Approx. 1.3 kg (2.86 lb)
• Metal casing, stainless steel	Approx. 3.9 kg (8.58 lb)
• Metal casing EEx d version	Approx. 5.2 kg (11.46 lb)
Dimensions	See "Dimensional drawings"
Climate class 4	To DIN EN 60721-3-4
• Storage ¹⁾	1K5, but -40 ... +80 °C (1K5, but -40 ... +176 °F)
• Transport ¹⁾	2K4, but -40 ... +80 °C (2K4, but -40 ... +176 °F)
• Operation ²⁾	4K3, but -30 ... +80 °C ³⁾ (4K3, but -22 ... +176 °F)

Certificate and approvals

Classification according to pressure equipment directive (DRGL 97/23/EC)	For gases of fluid group 1, complies with requirements of article 3, paragraph 3 (sound engineering practice SEP)
--	---

Pneumatic data

Power supply	Compressed air, nitrogen or cleaned natural gas
• Pressure	1.4 ... 7 bar (20.3 ... 101.5 psi): Sufficiently greater than max. drive pressure (actuating pressure)
Air quality to ISO 8573-1	
• Solid particle size and density	Class 2
• Pressure dew point	Class 2 (min. 20 K (36 °F) below ambient temperature)
• Oil content	Class 2
Unthrottled flow	
• Inlet air valve (ventilate actuator) ⁴⁾	
- 2 bar (29 psi)	4.1 Nm ³ /h (18.1 USgpm)
- 4 bar (58 psi)	7.1 Nm ³ /h (31.3 USgpm)
- 6 bar (87 psi)	9.8 Nm ³ /h (43.1 USgpm)
• Outlet air valve (exhaust actuator) ⁴⁾	
- 2 bar (29 psi)	8.2 Nm ³ /h (36.1 USgpm)
- 4 bar (58 psi)	13.7 Nm ³ /h (60.3 USgpm)
- 6 bar (87 psi)	19.2 Nm ³ /h (84.5 USgpm)
Valve leakage	< 6·10 ⁻⁴ Nm ³ /h (0.0026 USgpm)
Throttle ratio	Adjustable up to ∞ : 1
Power consumption in the controlled state	< 3.6·10 ⁻² Nm ³ /h (0.158 USgpm)
Types of actuators	
• In casing	Single-action and double-action
• In aluminium casing	Single-action
• In flameproof casing	Single-action and double-action
• In stainless steel casing	Single-action and double-action

- 1) During commissioning at ≤ 0 °C (≤ 32 °F) make sure that the valves are flushed long enough with the dry medium.
- 2) At ≤ -10 °C (14 °F) the display refresh rate of the LCD is limited. Only T4 is permissible when using I_y module.
- 3) -25 ... +75 °C (-13 ... +167 °F) for 6DR55..-0G..., 6DR56..-0G..., 6DR55..-0D... and 6DR56..-0D...
- 4) With EEx d version (6DR5..5-...) the values are reduced by approx. 20%.

Technical specifications

SIPART PS2	Basic device without Ex protection	Basic device with Ex d protection (flameproof casing)	Basic device with Ex ia/ib protection	Basic device with Ex n/dust protection
Explosion protection to ATEX	Without	Ex d II 2 G Ex d II C T6	Ex ia/ib II 2 G Ex ia/ib II C T6	Ex n II 3 G Ex nA nL[nL] IIC T6 Dust II 3 D Ex tD A22 IP66 T100°C
Mounting location		Zone 1	Zone 1	Zone 2/22
Permissible ambient temperature for operation	-30 ... +80 °C (-22 ... +176 °F)		T4: -30 ... +80 °C (-22 ... +176 °F) T5: -30 ... +65 °C (-22 ... +149 °F) T6: -30 ... +50 °C (-22 ... +122 °F)	
At ≤ -10 °C (+14 °F) the display refresh rate of the LCD is limited. (for basic devices with EEX ia/ib and EEx n protection the following applies: Only T4 is permissible when using I _y module.)				

Electrical data

Input

2-wire connection (terminals 6/8)

Rated signal range	4 ... 20 mA	4 ... 20 mA	4 ... 20 mA	4 ... 20 mA
Current to maintain the power supply	≥ 3.6 mA	≥ 3.6 mA	≥ 3.6 mA	≥ 3.6 mA
Required load voltage U _B (corresponds to Ω at 20 mA)				
• Without HART (6DR50..)				
- Typical	6.36 V (corresponds to 318 Ω)	6.36 V (corresponds to 318 Ω)	7.8 V (corresponds to 390 Ω)	7.8 V (corresponds to 390 Ω)
- Max.	6.48 V (corresponds to 324 Ω)	6.48 V (corresponds to 324 Ω)	8.3 V (corresponds to 415 Ω)	8.3 V (corresponds to 415 Ω)
• Without HART (6DR53..)				
- Typical	7.9 V (corresponds to 395 Ω)	–	–	–
- Max.	8.4 V (corresponds to 420 Ω)	–	–	–
• With HART (6DR51..)				
- Typical	6.6 V (corresponds to 330 Ω)	6.6 V (corresponds to 330 Ω)	–	–
- Max.	6.72 V (corresponds to 336 Ω)	6.72 V (corresponds to 336 Ω)	–	–
• With HART (6DR52..)				
- Typical	–	8.4 V (corresponds to 420 Ω)	8.4 V (corresponds to 420 Ω)	8.4 V (corresponds to 420 Ω)
- Max.	–	8.8 V (corresponds to 440 Ω)	8.8 V (corresponds to 440 Ω)	8.8 V (corresponds to 440 Ω)
• Static destruction limit	± 40 mA	–	–	–
Internal capacitance C _i				
• Without HART	–	–	22 nF	22 nF (at "nL")
• With HART	–	–	7 nF	7 nF (at "nL")
Internal inductance L _i				
• Without HART	–	–	0.12 mH	0.12 mH (at "nL")
• With HART	–	–	= 0.24 mH	0.24 mH (at "nL")
For connection to power circuits with the following max. ratings	–	–	intrinsically safe U _i = 30 V DC I _i = 100 mA P _i = 1 W	at "nA" and "tD": U _n = 30 V DC I _n = 100 mA at "nL": U _i = 30 V DC I _i = 100 mA

Electropneumatic positioners

SIPART PS2

Technical specifications

SIPART PS2

SIPART PS2	Basic device without Ex protection	Basic device with Ex d protection (flameproof casing)	Basic device with Ex ia/ib protection	Basic device with Ex n/dust protection
3-/4-wire device (terminals 2/4 and 6/8) (6DR52.. and 6DR53..)				
<ul style="list-style-type: none"> • Power supply U_H • Current consumption I_H • Internal capacitance C_i • Internal inductance L_i For connection to power circuits with the following max. ratings	18 ... 35 V DC $(U_H - 7.5 \text{ V})/2.4 \text{ k}\Omega$ [mA]	18 ... 35 V DC $(U_H - 7.5 \text{ V})/2.4 \text{ k}\Omega$ [mA]	18 ... 30 V DC $(U_H - 7.5 \text{ V})/2.4 \text{ k}\Omega$ [mA]	18 ... 30 V DC $(U_H - 7.5 \text{ V})/2.4 \text{ k}\Omega$ [mA]
Current input I_W	0/4 ... 20 mA	0/4 ... 20 mA	0/4 ... 20 mA	0/4 ... 20 mA
Rated signal range	$\leq 0.2 \text{ V}$ (corresponds to 10 Ω)	$\leq 0.2 \text{ V}$ (corresponds to 10 Ω)	$\leq 1 \text{ V}$ (corresponds to 50 Ω)	$\leq 1 \text{ V}$ (corresponds to 50 Ω)
Load voltage at 20 mA	–	–	22 nF	22 nF (at "nL")
Internal capacitance C_i	–	–	0.12 mH	0.12 mH (at "nL")
Internal inductance (L_i)	–	–	intrinsically safe	at "nA" and "tD":
For connection to power circuits with the following max. ratings	–	–	$U_i = 30 \text{ V DC}$	$U_n = 30 \text{ V DC}$
			$I_i = 100 \text{ mA}$	$I_n = 100 \text{ mA}$
			$P_i = 1 \text{ W}$	at "nL":
				$U_i = 30 \text{ V DC}$
				$I_i = 100 \text{ mA}$
Electrical isolation	between U_H and I_W	between U_H and I_W	between U_H and I_W (2 intrinsically safe circuits)	between U_H and I_W
Test voltage	840 V DC (1 s)	840 V DC (1 s)	840 V DC (1 s)	840 V DC (1 s)
Connections				
• Electric	Screw terminals 2.5 AWG28-12 Cable gland M20 x 1.5 or 1/2-14 NPT	Screw terminals 2.5 AWG28-12 EEx d certified cable gland M20 x 1.5, 1/2-14 NPT or M25 x 1.5	Screw terminals 2.5 AWG28-12 Cable gland M20 x 1.5 or 1/2-14 NPT	Screw terminals 2.5 AWG28-12 Cable gland M20 x 1.5 or 1/2-14 NPT
• Pneumatic	Female thread G1/4 DIN EN ISO 228-1 or 1/4-18 NPT	Female thread G1/4 DIN EN ISO 228-1 or 1/4-18 NPT	Female thread G1/4 DIN EN ISO 228-1 or 1/4-18 NPT	Female thread G1/4 DIN EN ISO 228-1 or 1/4-18 NPT
External position sensor (potentiometer or NCS; as option) with the following max. ratings				
• U_o	–	–	5 V	5 V
• I_o (static)	–	–	75 mA	75 mA
• I_s (short-time)	–	–	160 mA	–
• P_o	–	–	120 mW	120 mW
Maximum permissible external capacitance C_o	–	–	1 μF	1 μF
Maximum permissible external inductance L_o	–	–	1 mH	1 mH

Technical specifications

SIPART PS2 PA	Basic device without Ex protection	Basic device with Ex d protection (flameproof casing)	Basic device with Ex ia/ib protection	Basic device with Ex n/dust protection
Explosion protection to ATEX	Without	Ex d II 2 G Ex d II C T4/T5/T6	Ex ia/ib II 2 G Ex ia/ib II C T6	Ex n II 3 G Ex nA nL[nL] IIC T6 Dust II 3 D Ex tD A22 IP66 T100°C
Mounting location		Zone 1	Zone 1	Zone 2/22
Permissible ambient temperature for operation	-30 ... +80 °C (-22 ... +176 °F)	T4: -30 ... +80 °C (-22 ... +176 °F) T5: -30 ... +65 °C (-22 ... +149 °F) T6: -30 ... +50 °C (-22 ... +122 °F)	T4: -30 ... +80 °C (-22 ... +176 °F) T5: -30 ... +65 °C (-22 ... +149 °F) T6: -30 ... +50 °C (-22 ... +122 °F)	T4: -20 ... +75 °C (-4 ... +167 °F) T5: -20 ... +65 °C (-4 ... +149 °F) T6: -20 ... +50 °C (-4 ... +122 °F)
At ≤ -10 °C (+14 °F) the display refresh rate of the LCD is limited. (for basic devices with Ex protection the following applies: Only T4 is permissible when using I _y module.)				

Electrical data

Input

Power supply (terminals 6/7)	Bus-supplied	Bus-supplied	Bus-supplied	Bus-supplied
Bus voltage	9 ... 32 V	9 ... 32 V	9 ... 24 V	9 ... 32 V
• Bus connection with supply unit		–	Intrinsically safe FISCO	at "nA" and "tD": Un = 32 V DC at "nL": FNICO
- Max. supply voltage U _o	–	–	17.5 V	17.5 V
- Max. short-circuit current I _o	–	–	380 mA	570 mA
- Max. power P _o	–	–	5.32 W	–
• Bus connection with barrier		–	intrinsically safe	at "nL"
- Max. supply voltage (U _o)	–	–	24 V	32 V
- Max. short-circuit current (I _o)	–	–	250 mA	–
- Max. power P _o	–	–	1.2 W	–
Current consumption	11.5 mA ± 10%	11.5 mA ± 10%	11.5 mA ± 10%	11.5 mA ± 10%
Additional fault current	0 mA	0 mA	0 mA	0 mA
Effective internal inductance L _i	–	–	8 µH	8 µH (at "nL")
Effective internal capacitance C _i	–	–	Negligible	Negligible
Safety shutdown can be activated with coding bridge (terminals 81/82; electrically isolated from the basic device)				
• Input resistance	> 20 kΩ	> 20 kΩ	> 20 kΩ	> 20 kΩ
• Signal status "0" (shutdown active)	0 ... 4.5 V or unused	0 ... 4.5 V or unused	0 ... 4.5 V or unused	0 ... 4.5 V or unused
• Signal status "1" (shutdown not active)	13 ... 30 V	13 ... 30 V	13 ... 30 V	13 ... 30 V
• Effective Internal capacitance C _i	–	–	Negligible	Negligible
• Effective internal inductance L _i	–	–	Negligible	Negligible
• For connection to power supply with			Intrinsically safe	At "nA", "nL" and "tD"
- Max. supply voltage U _i	–	–	30 V	30 V
- Max. short-circuit current I _i	–	–	100 mA	100 mA
- Maximum power P _i	–	–	1 W	–
Electrical isolation	Between basic device and the input for safety shutdown, as well as the outputs of the option modules	Between basic device and the input for safety shutdown, as well as the outputs of the option modules	The basic device and the input to the safety shutdown, as well as the outputs of the option modules, are individual, intrinsically-safe circuits	Between basic device and the input for safety shutdown, as well as the outputs of the option modules
Test voltage	840 V DC, 1 s	840 V DC, 1 s	840 V DC, 1 s	840 V DC, 1 s

Electropneumatic positioners

SIPART PS2

Technical specifications

SIPART PS2 PA

SIPART PS2 PA	Basic device without Ex protection	Basic device with Ex d protection (flameproof casing)	Basic device with Ex ia/ib protection	Basic device with Ex n/dust protection
Communication	Layers 1 and 2 according to PROFIBUS PA, transmission technique according to IEC 1158-2; slave function; layer 7 (protocol layer) according to PROFIBUS DP, EN 50170 standard with the extended PROFIBUS functions (all data acyclic, manipulated variable, feedbacks and status also cyclic)			
C2 connections	Four connections to master class 2 are supported, automatic connection setup 60 s after break in communication			
Device profile	PROFIBUS PA profile B, version 3.0, more than 150 objects			
Response time to master message	Typical 10 ms			
Device address	126 (when delivered)			
PC parameterizing software	SIMATIC PDM; supports all device objects. The software is not included in the scope of delivery.			
Connections				
• Electric	Screw terminals 2.5 AWG28-12 Cable gland M20 x 1.5 or ½-14 NPT	Screw terminals 2.5 AWG28-12 EEx d certified cable gland M20 x 1.5, ½-14 NPT or M25 x 1.5	Screw terminals 2.5 AWG28-12 Cable gland M20 x 1.5 or ½-14 NPT	Screw terminals 2.5 AWG28-12 Cable gland M20 x 1.5 or ½-14 NPT
• Pneumatic	Female thread G¼ DIN EN ISO 228-1 (¼-18 NPT)	Female thread G¼ DIN EN ISO 228-1 (¼-18 NPT)	Female thread G¼ DIN EN ISO 228-1 (¼-18 NPT)	Female thread G¼ DIN EN ISO 228-1 (¼-18 NPT)
External position sensor (potentiometer or NCS; as option) with the following max. ratings				
• U _o	–	–	5 V	5 V
• I _o (static)	–	–	75 mA	75 mA
• I _s (short-time)	–	–	160 mA	–
• P _o	–	–	120 mW	120 mW
• Maximum permissible external capacitance C _o	–	–	1 µF	1 µF
• Maximum permissible external inductance L _o	–	–	1 mH	1 mH

Technical specifications

SIPART PS2 FF	Basic device without Ex protection	Basic device with Ex d protection (flameproof casing)	Basic device with Ex ia/ib protection	Basic device with Ex n/dust protection
Explosion protection to ATEX	Without	Ex d II 2 G Ex d II C T4/T5/T6	Ex ia/ib II 2 G Ex ia/ib II C T6	Ex n II 3 G Ex nA nL[nL] IIC T6 Dust II 3 D Ex tD A22 IP66 T100°C
Mounting location		Zone 1	Zone 1	Zone 2/22
Permissible ambient temperature for operation	-30 ... +80 °C (-22 ... +176 °F)	T4: -30 ... +80 °C (-22 ... +176 °F) T5: -30 ... +65 °C (-22 ... +149 °F) T6: -30 ... +50 °C (-22 ... +122 °F)	T4: -30 ... +80 °C (-22 ... +176 °F) T5: -30 ... +65 °C (-22 ... +149 °F) T6: -30 ... +50 °C (-22 ... +122 °F)	T4: -20 ... +75 °C (-4 ... +167 °F) T5: -20 ... +65 °C (-4 ... +149 °F) T6: -20 ... +50 °C (-4 ... +122 °F)
At ≤ -10 °C (+14 °F) the display refresh rate of the LCD is limited. (for basic devices with Ex protection the following applies: Only T4 is permissible when using I _y module.)				

Electrical data

Input

Power supply (terminals 6/7)	Bus-supplied	Bus-supplied	Bus-supplied	Bus-supplied
Bus voltage	9 ... 32 V	9 ... 32 V	9 ... 24 V	9 ... 32 V
• Bus connection with supply unit		–	Intrinsically safe FISCO	at "nA" and "tD": Un = 32 V DC at "nL": FNICO
- Max. supply voltage U _o	–	–	17.5 V	17.5 V
- Max. short-circuit current I _o	–	–	380 mA	570 mA
- Max. power P _o	–	–	5.32 W	–
• Bus connection with barrier	–	–	intrinsically safe	at "nL"
- Max. supply voltage (U _o)	–	–	24 V	32 V
- Max. short-circuit current (I _o)	–	–	250 mA	–
- Max. power P _o	–	–	1.2 W	–
Current consumption	11.5 mA ± 10%	11.5 mA ± 10%	11.5 mA ± 10%	11.5 mA ± 10%
Additional fault current	0 mA	0 mA	0 mA	0 mA
Effective internal inductance L _i	–	–	8 µH	8 µH (at "nL")
Effective internal capacitance C _i	–	–	Negligible	Negligible
Safety shutdown can be activated with coding bridge (terminals 81/82; electrically isolated from the basic device)				
• Input resistance	> 20 kΩ	> 20 kΩ	> 20 kΩ	> 20 kΩ
• Signal status "0" (shutdown active)	0 ... 4.5 V or unused	0 ... 4.5 V or unused	0 ... 4.5 V or unused	0 ... 4.5 V or unused
• Signal status "1" (shutdown not active)	13 ... 30 V	13 ... 30 V	13 ... 30 V	13 ... 30 V
• Effective Internal capacitance C _i	–	–	Negligible	Negligible
• Effective internal inductance L _i	–	–	Negligible	Negligible
• For connection to power supply with	–	–	Intrinsically safe	At "nA", "nL" and "tD"
- Max. supply voltage U _i	–	–	30 V	30 V
- Max. short-circuit current I _i	–	–	100 mA	100 mA
- Maximum power P _i	–	–	1 W	–
Electrical isolation	Between basic device and the input for safety shutdown, as well as the outputs of the option modules	Between basic device and the input for safety shutdown, as well as the outputs of the option modules	The basic device and the input to the safety shutdown, as well as the outputs of the option modules, are individual, intrinsically-safe circuits	Between basic device and the input for safety shutdown, as well as the outputs of the option modules
Test voltage	840 V DC, 1 s	840 V DC, 1 s	840 V DC, 1 s	840 V DC, 1 s

Electropneumatic positioners

SIPART PS2

Technical specifications SIPART PS2 FF

SIPART PS2 FF	Basic device without Ex protection	Basic device with Ex d protection (flameproof casing)	Basic device with Ex ia/ib protection	Basic device with Ex n/dust protec- tion
Communication				
Communications group and class	According to technical specification of the Fieldbus Foundation for H1 communication			
Function blocks	Group 3, Class 31PS (publisher, subscriber) 1 resource block (RB2) 1 analog output function block (AO) 1 PID function block (PID) 1 transducer block (standard advanced positioner valve)			
Execution times of the blocks	AO: 50 ms PID: 80 ms			
Physical layer profile	123, 511			
FF registration	Tested with ITK 5.0			
Device address	22 (when delivered)			
Connections				
Electric	Screw terminals 2.5 AWG28-12	Screw terminals 2.5 AWG28-12	Screw terminals 2.5 AWG28-12	Screw terminals 2.5 AWG28-12
	Cable gland M20 x 1.5 or ½-14 NPT	EEx d certified cable gland M20 x 1.5, ½-14 NPT or M25 x 1.5	Cable gland M20 x 1.5 or ½-14 NPT	Cable gland M20 x 1.5 or ½-14 NPT
Pneumatic	Female thread G¼ DIN EN ISO 228-1 (¼-18 NPT)	Female thread G¼ DIN EN ISO 228-1 (¼-18 NPT)	Female thread G¼ DIN EN ISO 228-1 (¼-18 NPT)	Female thread G¼ DIN EN ISO 228-1 (¼-18 NPT)
External position sensor (potentiometer or NCS; as option)				
• U _o	–	–	< 5 V	< 5 V
• I _o	–	–	< 75 mA	< 75 mA
• I _s	–	–	< 160 mA	< 160 mA
• P _o	–	–	< 120 mW	< 120 mW
Maximum permissible external capaci- tance C _o	–	–	< 1 µF	< 1 µF
Maximum permissible external induc- tance L _o	–	–	< 1 mH	< 1 mH

Technical specifications

Option modules	Without Ex protection (EEx d also)	With Ex protection Ex ia/ib	With Ex n/dust protection
Ex protection to ATEX	–	II 2G Ex ia/ib II C T4/T5/T6 (only in conjunction with)	Ex n II 3 G Ex nA nL[nL] IIC T6 Dust II 3 D Ex tD A22 IP66 T100°C
Mounting location	–	Zone 1	Zone 2/22
Permissible ambient temperature for operation (For devices with Ex protection: Only in conjunction with the basic device 6DR5...-E..... Only T4 is permissible when using I _y module)	-30 ... +80 °C (-22 ... +176 °F)	T4: -30 ... +80 °C (-22 ... +176 °F) ¹⁾ T5: -30 ... +65 °C (-22 ... +149 °F) ¹⁾ T6: -30 ... +50 °C (-22 ... +122 °F) ¹⁾	
Alarm module	6DR4004-8A (without Ex protection)	6DR4004-6A (with Ex protection)	6DR4004-6A (with Ex protection)
Binary alarm outputs A1, A2 and alarm output			
Signal status High (not responded)	Active, R = 1 kΩ, +3/-1%*	≥ 2.1 mA	≥ 2.1 mA
Signal status Low* (responded)	Disabled, I _R < 60 μA	≤ 1.2 mA	≤ 1.2 mA
(* Low is also the status when the basic device is faulty or has not electric power supply)	(* When used in the flameproof casing the current consumption is limited to 10 mA per output.)	(Switching threshold with supply to EN 60947-5-6: U _H = 8.2 V, R _I = 1kΩ)	(Switching threshold with supply to EN 60947-5-6: U _H = 8.2 V, R _I = 1kΩ)
Internal capacitance C _i	–	5.2 nF	5.2 nF (at "nL")
Internal inductance L _i	–	Negligible	Negligible
Power supply U _H	≤ 35 V	–	–
Connection to power circuits with the following max. ratings	–	intrinsically safe switching amplifier EN 60947-5-6 U _O = 15.5 V DC I _k = 25 mA, P = 64 mW	at "nA" and "tD": U _n = 15.5 V DC at "nL": U _i = 15.5 V DC I _i = 25 mA
Binary input BE2			
• Electrically connected to the basic device			
- Signal status 0	Floating contact, open	Floating contact, open	Floating contact, open
- Signal status 1	Floating contact, closed	Floating contact, closed	Floating contact, closed
- Contact load	3 V, 5 μA	3 V, 5 μA	3 V, 5 μA
• Electrically isolated from the basic device			
- Signal status 0	≤ 4.5 V or open	≤ 4.5 V or open	≤ 4.5 V or open
- Signal status 1	≥ 13 V	≥ 13 V	≥ 13 V
- Natural resistance	≥ 25 kΩ	≥ 25 kΩ	≥ 25 kΩ
Static destruction limit	± 35 V	–	–
Internal inductance and capacitance	–	Negligible	Negligible
Connection to power circuits with the following max. ratings	–	Intrinsically safe U _i = 25.2 V	at "nA" and "tD": U _n = 25.2 V DC at "nL": U _i = 25.2 V DC
Electrical isolation	The 3 outputs, the input BE2 and the basic device are electrically isolated from each other.		
Test voltage	840 V DC, 1 s	840 V DC, 1 s	840 V DC, 1 s

¹⁾ Only in conjunction with the basic device 6DR5...-E..... With I_y module only T4 permitted.

Electropneumatic positioners

SIPART PS2

Technical specifications

Option modules

Option modules	Without Ex protection	With Ex protection EEx ia/ib	With Ex n/dust protection
SIA module Limit switches with slot-type initiators and alarm output	6DR4004-8G (without Ex protection) (not for Ex-d version)	6DR4004-6G (with Ex protection)	6DR4004-6G (with Ex protection)
<u>Limit switches A1, A2</u>	2-wire connection	2-wire connection	2-wire connection
Ex protection	Without	II 2 G EEx ia/ib IIC T6	II 3 G EEx nA L [L] IIC T6
Connection	2-wire system to EN 60947-5-6 (NAMUR), for switching amplifier to be connected on load side		
2 slot-type initiators	Type SJ2-SN	Type SJ2-SN	Type SJ2-SN
Function	NC (normally closed)	NC (normally closed)	NC (normally closed)
Connection to power circuits with the following max. ratings	nominal voltage 8 V Current consumption: ≥ 3 mA (limit value not responded) ≤ 1 mA (limit value responded)	intrinsically safe switching amplifier EN 60947-5-6 U _i = 15.5 V DC I _i = 25 mA, P _i i = 64 mW	at "nA" and "tD": U _n = 15.5 V DC P _n = 64 mW at "nL": U _i = 15.5 V DC I _i = 25 mA
Internal capacitance	–	41 nF	41 nF (at "nL")
Internal inductance	–	100 mH	100 mH (at "nL")
Electrical isolation	The 3 outputs are electrically isolated from the basic device.		
Test voltage	840 V DC, 1 s	840 V DC, 1 s	840 V DC, 1 s
<u>Alarm output</u>	2-wire system to EN 60947-5-6 (NAMUR), for switching amplifier to be connected on load side U _H = 8.2 V, R _i = 1 kΩ		
Connection			
Signal status High (not active)	R = 1.1 kΩ	≥ 2.1 mA	≥ 2.1 mA
Signal status Low (active)	R _i = 10 kΩ	≤ 1.2 mA	≤ 1.2 mA
Internal capacitance C _i	–	5.2 nF	5.2 nF (bei „nL“)
Internal Inductance L _i	–	Negligible	Negligible
Power supply U _H	U _H ≤ 35 V DC, I ≤ 20 mA	–	–
For connection to power with the following max. ratings	–	intrinsically safe switching amplifier EN 60947-5-6 U _i = 15.5 V DC I _i = 25 mA P _i = 64 mW	at „nA“ and „tD“: U _n = 15.5 V DC at „nL“: U _i = DC 15.5 V I _i = 25 mA
Limit value contact module Limit switches with mechanical ground contact and alarm output	6DR4004-8K (not for EEx d version)	6DR4004-6K	6DR4004-6K
<u>Limit switches A1, A2</u>			
Ex protection	without	II 2 G Ex ia/ib IIC T6	II 3 G Ex nL [nL] IIC T6 (in progress)
Max. switching current AC/DC	4 A	Connection to intrinsically safe circuit with maximum values: U _i = 30 V, I _i = 100 mA, P _i = 750 mW	Connection to circuits with maximum values: at "nL": U _i = 30 V I _i = 100 mA,
Max. switching voltage AC/DC	250 V / 24 V	30 V DC	
Internal capacitance C _i	–	Negligible	Negligible
Internal inductance L _i	–	Negligible	Negligible
Electrical isolation	The 3 outputs are electrically isolated from the basic device.		
Test voltage	3150 V DC, 2s	3150 V DC, 2 s	3150 V DC, 2 s
<u>Alarm output</u>	2-wire system to EN 60947-5-6 (NAMUR), for switching amplifier to be connected on load side U _H = 8.2 V, R _i = 1 kΩ		
Connection			
Signal status High (not active)	R = 1.1 kΩ	≥ 2.1 mA	≥ 2.1 mA
Signal status Low (active)	R _i = 10 kΩ	≤ 1.2 mA	≤ 1.2 mA
Internal capacitance C _i	–	5.2 nF	5.2 nF (bei „nL“)
Internal Inductance L _i	–	Negligible	Negligible
Power supply U _H	U _H ≤ 35 V DC, I ≤ 20 mA	–	–
For connection to power with the following max. ratings	–	Intrinsically safe switching amplifier EN 60947-5-6 U _i = 15.5 V DC I _i = 25 mA P _i = 64 mW	at „nL“: U _i = 15.5 V DC I _i = 25 mA

Option modules	Without Ex protection	With Ex protection EEx ia/ib	With Ex n/dust protection
I_y module	6DR4004-8J (without Ex protection)	6DR4004-6J (with Ex protection)	6DR4004-6J (with Ex protection)
DC output for position feedback	2-wire connection	2-wire connection	2-wire connection
Nominal signal range	4 ... 20 mA, short-circuit-proof	4 ... 20 mA, short-circuit-proof	4 ... 20 mA, short-circuit-proof
Total operating range	3.6 ... 20.5 mA	3.6 ... 20.5 mA	3.6 ... 20.5 mA
Power supply U _H	+12 ... +35 V	+12 ... +30 V	+12 ... +30 V
External load R _B [kΩ]	≤ (U _H [V] - 12 V) / i [mA]	≤ (U _H [V] - 12 V) / i [mA]	≤ (U _H [V] - 12 V) / i [mA]
Transmission error	≤ 0.3%	≤ 0.3%	≤ 0.3%
Temperature effect	≤ 0.1%/10 K (≤ 0.1%/18 °F)	≤ 0.1%/10 K (≤ 0.1%/18 °F)	≤ 0.1%/10 K (≤ 0.1%/18 °F)
Resolution	≤ 0.1%	≤ 0.1%	≤ 0.1%
Residual ripple	≤ 1%	≤ 1%	≤ 1%
Internal capacitance C _i	–	11 nF	11 nF (at "nL")
Internal inductance L _i	–	Negligible	Negligible
For connection to power circuits with the following max. ratings		Intrinsically safe: U _i = 30 V DC I _i = 100 mA P _i = 1 W (only T4)	at "nA" and "tD" U _n = 30 V DC I _n = 100 mA P _n = 1 W (only T4) at "nL": U _i = 30 V DC I _i = 100 mA
Electrical isolation	Electrically isolated from the basic device	Electrically isolated from the basic device	Electrically isolated from the basic device
Test voltage	840 V DC, 1 s	840 V DC, 1 s	840 V DC, 1 s
NCS sensor (not for EEx d version)			
Position range			
• Linear actuator	3 ... 130 mm (0.12 ... 5.12 inch), to 200 mm (7.87 inch) on request	3 ... 130 mm (0.12 ... 5.12 inch), to 200 mm (7.87 inch) on request	
• Part-turn actuator	30° ... 100°	30° ... 100°	
Linearity (after correction by SIPART PS2)			
• Linear actuator	± 1%	± 1%	
• Part-turn actuator	± 1%	± 1%	
Hysteresis	± 0.2%	± 0.2%	
Continuous working temperature	-40 ... +85 °C (-40 ... +185 °F), extended temperature range on request	-40 ... +85 °C (-40 ... +185 °F), extended temperature range on request	
For connection to power circuits with the following max. ratings		Intrinsically safe U _i = 5 V DC	at "nL": U _i = 5 V DC
Internal capacitance C _i	–	10 nF	10 nF (at "nL")
Internal inductance L _i	–	240 mH	240 mH (at "nL")
Degree of protection of casing	IP68/NEMA 4X	IP68/NEMA 4X	

Electropneumatic positioners

SIPART PS2

Ordering data

SIPART PS2, PS2 PA, PS2 FF

Selection and Ordering data	Order No.
Electropneumatic positioner SIPART PS2, Ex protection without, EEx ia/ib and EEx n	6 DR 5 - 0 - - - A
Version 2-wire (4 to 20 mA)	
• Without HART	0
• With HART, <u>not</u> explosion-protected	1
2-, 3-, 4-wire (0/4 to 20 mA)	
• With HART, explosion-protected	2
• Without HART, <u>not</u> explosion-protected	3
PROFIBUS PA connection	5
FOUNDATION Fieldbus connection	6
For actuator	
Single-action	1
Double-action	2
Casing	
Plastic	0
Aluminum; only single-action	1
Stainless steel (without window)	2
Explosion protection	
Without	N
With explosion protection EEx ia/ib (CENELEC/ATEX/FM/CSA)	E
With explosion protection EEx n, (CENELEC/ATEX)	
• For zone 2 and zone 22 (dust), casing: aluminium or stainless steel; each with no window in the cover	D
• For zone 2 ¹⁾²⁾ casing: aluminium or plastic; each with window in the cover	G
Connection thread electrical/pneumatic	
M20 x 1.5 / G¼	G
½-14 NPT / ¼-18 NPT	N
M20 x 1.5 / ¼-18 NPT	M
½-14 NPT / G¼	P
With plug M12 / G¼	R
With plug M12 / ¼-18 NPT	S
Limit monitor	
Installed, incl. 2nd cable gland	
Without	0
Alarm module; electronic (6DR4004-.A)	1
SIA module; slot-type initiators (6DR4004-.G)	2
Limit value contact module (mechanical switching contacts (6DR4004-.K)	3

Selection and Ordering data	Order No.
Electropneumatic positioner SIPART PS2, Ex protection without, EEx ia/ib and EEx n	6 DR 5 - 0 - - - A
Optional modules	
Installed, incl. 2nd cable gland	
Without	0
ly module for position feedback signal (4 ... 20 mA) (6DR4004-.J)	1
EMC filter module for external position sensor (C73451-A430-D23)	2
ly module and EMC filter module for external position sensor	3
Customer-specific design	
Without	0
Brief instructions	
German/English	A
French/Spanish/Italian	B
Mounted pressure gauge block	
Without	0
Single-action G¼, scaling MPA and bar	1
Double-action G¼, scaling MPA and bar	2
Single-action ¼-18 NPT, scaling MPA and psi	3
Double-action ¼-18 NPT, scaling MPA and psi	4
Further designs	Order code
Add "-Z" to Order No. and specify Order code.	
Version with stainless steel sound absorbers	A40
standard with stainless steel enclo- sures	
Measuring point number (TAG No.)	Y17 ³⁾
HART tag max. 8 characters, max. 32 characters for PROFIBUS PA, FOUNDATION Field- bus and 4 ... 20 mA version, specify in plain text: Y17:	
Measuring point description	Y15 ³⁾
HART tag max. 16 characters, max. 32 characters for PROFIBUS PA, FOUNDATION Field- bus and 4 ... 20 mA version, specify in plain text: Y15:	
Measuring point text	Y16 ³⁾
HART tag max. 24 characters, max. 32 characters for PROFIBUS PA, FOUNDATION Field- bus and 4 ... 20 mA version, specify in plain text: Y16:	
TAG plate made of stainless steel, 3-line	A20 ³⁾
Text line 1: Plain text from Y17 Text line 2: Plain text from Y15 Text line 3: Plain text from Y16	
Preset bus address	Y25 ³⁾
Specify in plain text: Y25:	

► Available ex stock

- 1) Maximum impact energy to the casing: 1 Joule.
- 2) For device versions in plastic casing: it is essential to prevent electrostatic charging. Maximum torque of the cable gland: 67 Nm.
- 3) Only for plastic casing, for other casings on request.

Electropneumatic positioners

SIPART PS2

Ordering data
SIPART PS2 EEx-d, PS2 EEx-d PA, PS2 EEx-d FF

Selection and Ordering data	Order No.
Electropneumatic positioner SIPART PS2, Ex protection EEx-d, aluminium housing, without cable gland	6 DR 5 5 - 0 E - A
Version	
2-wire (4 to 20 mA)	
• <u>Without</u> HART	0
• <u>With</u> HART, <u>not</u> explosion-protected	1
2-, 3-, 4-wire (0/4 to 20 mA)	
• <u>With</u> HART	2
• <u>Without</u> HART, <u>not</u> explosion-protected	3
PROFIBUS PA connection	5
FOUNDATION Fieldbus connection	6
For actuator	
Single-action	1
Double-action	2
Connection thread electrical/pneumatic	
M20 x 1.5 / G¼	G
½-14 NPT / ¼-18 NPT	N
M20 x 1.5 / ¼-18 NPT	M
½-14 NPT / G¼	P
M25 x 1.5 / G¼	Q
Limit monitor	
Installed	
Without	0
Alarm module; electronic (6DR4004-.A)	1
Optional modules	
Installed	
Without	0
ly module for position feedback signal (4 ... 20 mA) (6DR4004-.J)	1
Customer-specific design	
Without	0
Brief instructions	
German/English	A
French/Spanish/Italian	B
Mounted pressure gauge block	
Without	0
Single-action G¼, scaling MPa and bar	1
Double-action G¼, scaling MPa and bar	2
Single-action ¼-18 NPT, scaling MPa and psi	3
Double-action ¼-18 NPT, scaling MPa and psi	4

Selection and Ordering data	Order No.
Electropneumatic positioner SIPART PS2, Ex protection EEx-d, aluminium housing, without cable gland	6 DR 5 5 - 0 E - A
Further designs	Order code
Add "-Z" to Order No. and specify Order Code.	
Measuring point number (TAG No.)	Y17
HART tag max. 8 characters, max. 32 characters for PROFIBUS PA and FOUNDATION Fieldbus version, specify in plain text: Y17:	
Measuring point description	Y15
HART tag max. 16 characters, max. 32 characters for PROFIBUS PA and FOUNDATION Fieldbus version, specify in plain text: Y15:	
Measuring point text	Y16
HART tag max. 24 characters, max. 32 characters for PROFIBUS PA and FOUNDATION Fieldbus version, specify in plain text: Y16:	
TAG plate made of stainless steel, 3-line	A20
Text line 1: Plain text from Y17 Text line 2: Plain text from Y15 Text line 3: Plain text from Y16	
Preset bus address	Y25
Specify in plain text: Y25:	

► Available ex stock

D) Subject to export regulations AL: N, ECCN: EAR99H

Electropneumatic positioners

SIPART PS2

Ordering data Accessories

Selection and Ordering data	Order No.
Accessories	
NCS sensor for non-contacting detection of position (not for EEx d version), cable length 6 m (19.68 ft)	6DR4004 - NN 0
Non explosion-proof	8
Explosion-protected, EEx ia/ib	6
For part-turn actuators, without mounting console	1
For linear actuators up to 14 mm (0.55 inch), without mounting bracket	2
For linear actuators > 14 mm (0.55 inch), to 130 mm (5.12 inch); Mounting kit same as for SIPART PS2 (separate ordering item)	3
The EMC filter module is additionally required for the controller unit. (separate order item, see below)	
Selection and Ordering data	
Accessories	
Alarm module for 3 alarm outputs and 1 binary input (functionality: 2 limit monitors, 1 fault alarm, 1 binary input)	
• Without explosion protection	▶ 6DR4004-8A
• With explosion protection CENELEC/ATEX	▶ 6DR4004-6A
• With explosion protection FM/CSA ¹⁾	6DR4004-7A
SIA module (slot-type initiator alarm module, not for EEx d version)	
• Without explosion protection	6DR4004-8G
• With explosion protection CENELEC/ATEX and FM/CSA ¹⁾	6DR4004-6G
Limit value contact module (with mechanical ground contacts, not for EEx d version)	
• without explosion protection	6DR4004-8K
• with explosion protection	6DR4004-6K
I_v module for position feedback signal (4 to 20 mA)	
• Without explosion protection	▶ 6DR4004-8J
• With explosion protection CENELEC/ATEX	▶ 6DR4004-6J
• With explosion protection FM/CSA ¹⁾	6DR4004-7J
HART modem for connecting to PC or laptop	
• with RS232 interface	▶ 7MF4997-1DA D)
• with USB interface	▶ 7MF4997-1DB D)
EMC filter module for connection of external position sensor (10 kΩ) or NCS sensor (not for EEx d version)	C73451-A430-D23

Mounting kit for NAMUR part-turn actuators

(VDI/VDE 3845, without mounting plate) ▶ **6DR4004-8D**

The following mounting plates can be used with the NAMUR part-turn actuator mounting kit 6DR4004-8D.

Size W x L x H (H = height of shaft butt)

- 30 x 80 x 20 mm ▶ **TGX:16152-105**
C)
- 30 x 80 x 30 mm ▶ **TGX:16300-147**
C)
- 30 x 130 x 30 mm ▶ **TGX:16300-149**
C)
- 30 x 130 x 50 mm ▶ **TGX:16300-151**
C)

Mounting kit for other part-turn actuators

The following mounting plates can be used together with the NAMUR part-turn actuator mounting kit 6DR4004-8D.

- SPX (DEZURIK) Power Rac, sizes R1, R1A, R2 and R2A ▶ **TGX:16152-328**
C)
- Masoneilan Camflex II ▶ **TGX:16152-350**
C)
- Fisher 1051/1052/1061, sizes 30, 40, 60 to 70 ▶ **TGX:16152-364**
C)
- Fisher 1051/1052, size 1033 ▶ **TGX:16152-348**
C)

Mounting kit for NAMUR linear actuators

- NAMUR linear actuator mounting kit with short lever arm (2 to 35 mm) ▶ **6DR4004-8V**
- Lever arm for travels from 35 mm to 130 mm (1.38 inch to 5.12 inch) ▶ **6DR4004-8L**
- Reduced mounting kit for linear actuator (without fixing angle and U-bracket), with short lever with up to 35 mm travel (1.38 inch) ▶ **6DR4004-8VK**
- Reduced mounting kit for linear actuator (without fixing angle and U-bracket), with long lever with >35 mm travel (1.38 inch) ▶ **6DR4004-8VL**

Mounting kit for other linear actuators

- Retrofitting kit for Moore series 72 and 750 valve positioners ▶ **TGX:16152-117**
C)
- Fisher type 657/667, size 30 to 80 ▶ **TGX:16152-110**
C)
- SAMSON actuator type 3277 (yoke dimension (H5) = 101 mm²⁾ (integrated connection without tube), not for EEx d ▶ **6DR4004-8S**

Pipe mounting

Mounting bracket for pipe mounting of the SIPART PS2 position (e.g. when using the NCS sensor) ▶ **TGX:16152-336**
C)

Additional actuator items can be found at the following Internet address:
www.siemens.com/sipartps2

Customer-specific actuators available on request.

▶ Available ex stock

¹⁾ U.S. certification by FM institute

²⁾ With a yoke dimension H5 = 95 mm, only the SIPART PS2 in a metal casing can be used.

C) Subject to export regulations AL: N, ECCN: EAR99

D) Subject to export regulations AL: N, ECCN: EAR99H

Electropneumatic positioners

SIPART PS2

Ordering data
Accessories

Manometer block including pressure gauge <ul style="list-style-type: none"> For single-action SIPART PS2 positioner with G thread (2 manometers, scaled in MPa and bar) ▶ For double-action SIPART PS2 positioner with G thread (3 manometers, scaled in MPa and bar) ▶ For single-action SIPART PS2 positioner with NPT thread (2 manometers, scaled in MPa and psi) ▶ For double-action SIPART PS2 positioner with NPT thread (3 manometers, scaled in MPa and psi) ▶ 	6DR4004-1M 6DR4004-2M 6DR4004-1MN 6DR4004-2MN
Connection block , for safety solenoid valve with extended mounting flange to NAMUR <ul style="list-style-type: none"> For mounting to IEC 534-6 For SAMSON actuator (integrated mounting) see above 	6DR4004-1B 6DR4004-1C¹⁾
External position detection system (with explosion protection to CENELEC/ATEX, EEx ia/ib) for separate mounting of position sensor and controller (for for EEx d version), comprising SIPART PS2 plastic casing with integral potentiometer and sliding clutch (without electronics and valve block) The EMC filter module is additionally required for the controller unit. (separate ordering item below)	C73451-A430-D78
Documentation (see notes below) Instruction Manual SIPART PS2 <ul style="list-style-type: none"> German/English French/Italian/Spanish 	A5E00074600 A5E00074601
Instruction Manual SIPART PS2 PROFIBUS PA <ul style="list-style-type: none"> German/English French/Italian/Spanish 	A5E00120716 A5E00120717
Instruction Manual NCS Sensor <ul style="list-style-type: none"> German/English/French/Spanish/Italian 	A5E00097485
SIPART PS2 device documentation <ul style="list-style-type: none"> CD-ROM with complete documentation for all device versions 	A5E00214567
Device manual for SIPART PS2 (not PA and FF) <ul style="list-style-type: none"> German English 	A5E00074630 A5E00074631
Manual for SIPART PS2 PROFIBUS PA <ul style="list-style-type: none"> German English 	A5E00127924 A5E00127926
SITRANS I outgoing isolator HART (see „SITRANS I supply units and isolation amplifiers“) with <ul style="list-style-type: none"> 24 V DC power supply 230 V AC power supply 	7NG4130-1AA11 7NG4130-1BA11

▶ Available ex stock

¹⁾ Only together with 6DR4004-8S and 6DR4004-1M.

Note

All the above mentioned manuals are included on CD-ROM or can be downloaded from the Internet under:

www.siemens.com/sipartps2

Following manuals are available in addition as downloads from the Internet or are included on CD-ROM:

- Instruction Manual Compact SIPART PS2 FF, Electropneumatic Positioner (6DR56xx) with FOUNDATION Fieldbus - German/English: A5E00214570
- Instruction Manual SIPART PS2 FF, Electropneumatic Positioner (6DR56xx) with FOUNDATION Fieldbus - German: A5E00214568 - English: A5E00214569

Scope of delivery:

- 1 SIPART PS2 positioner as ordered
- 1 CD-ROM with the complete documentation for all versions and accessories
- Manual "SIPART PS2 - Configuration At a Glance"

More information

Special versions

On request

Electropneumatic positioners

SIPART PS2

Dimensional drawings

Dimensional drawings

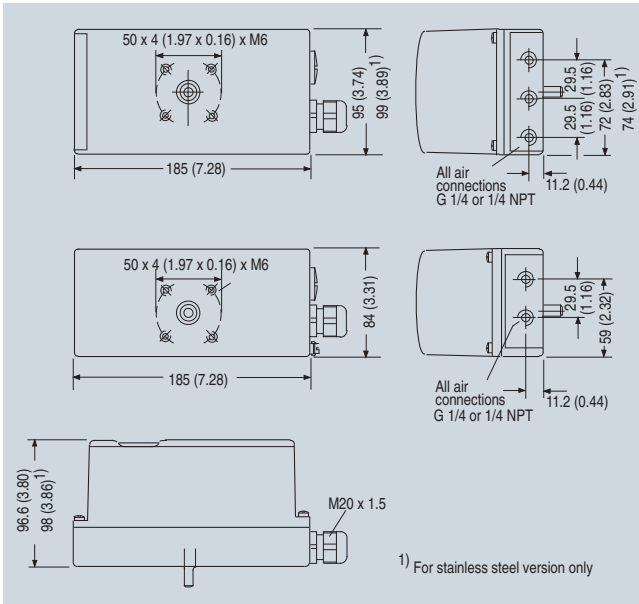

Plastic and stainless steel casing (top), aluminium casing (center), plastic and metal casing (bottom), dimensions in mm (inch)

6

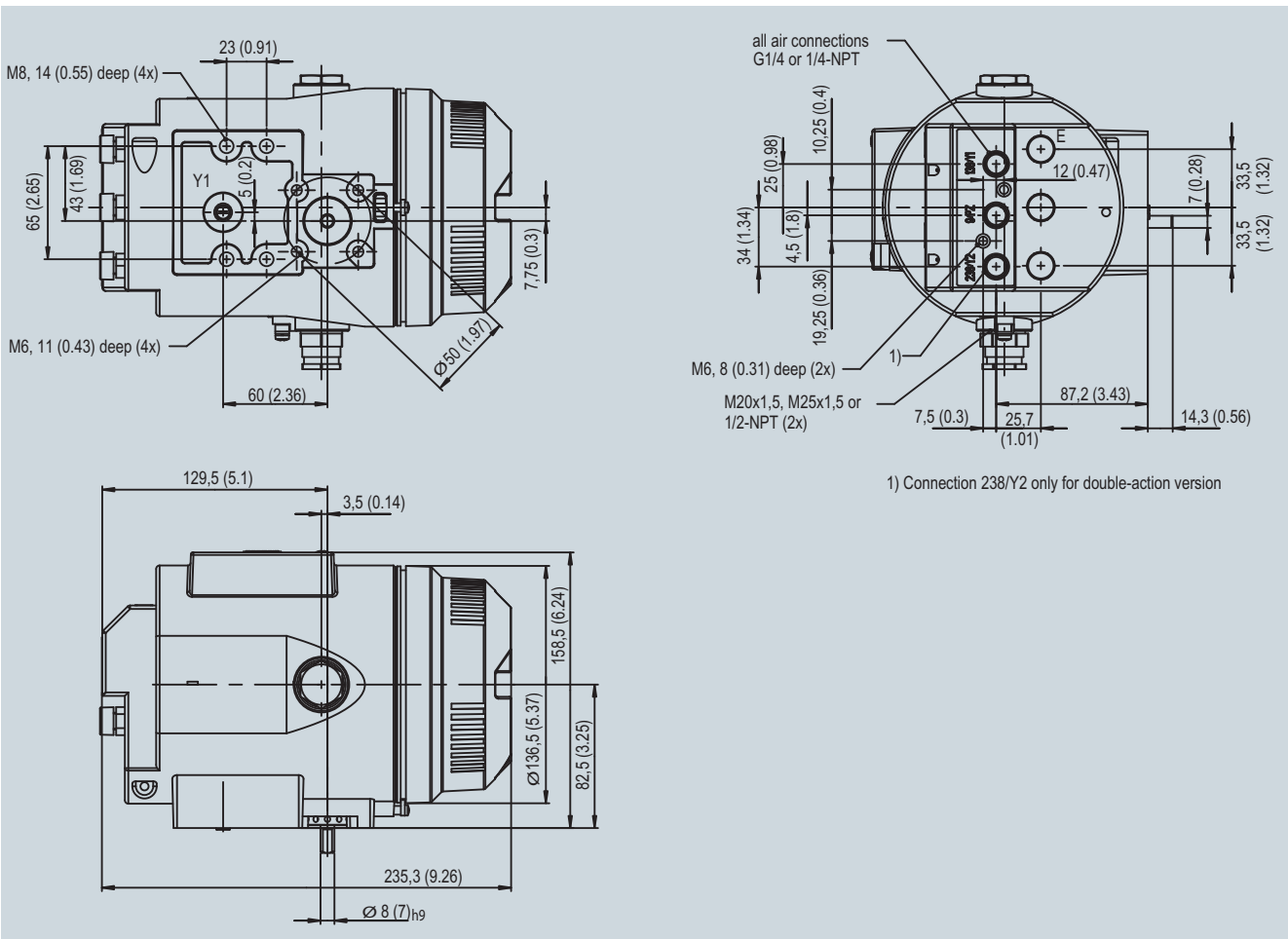

Flameproof casing left, dimensions in mm (inch)

Electropneumatic positioners

SIPART PS2

Schematics

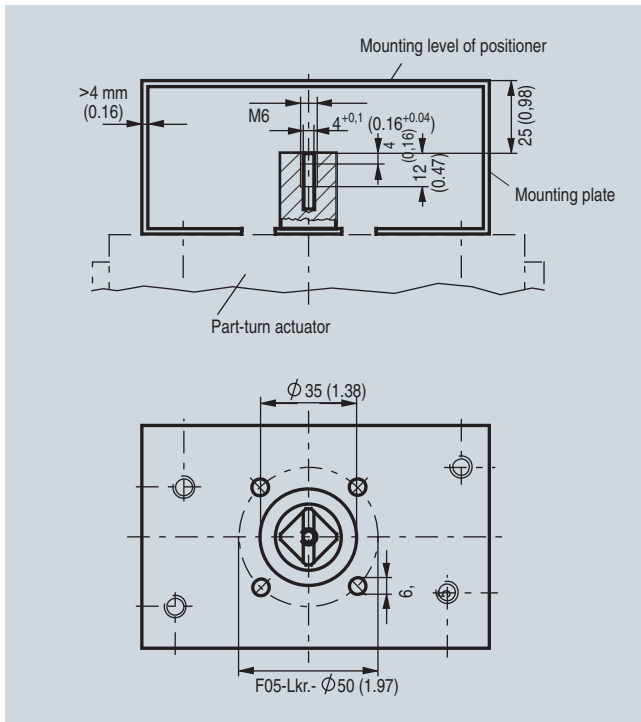

Mounting onto part-turn actuators; mounting plate (scope of delivery of actuator manufacturer), extract from VDI/VDE 3845, dimensions in mm (inch)

Schematics

Electric connection of 2-wire devices (6DR50.. and 6DR51..)

Devices of types 6DR50.. and 6DR51.. are operated in a 2-wire system.

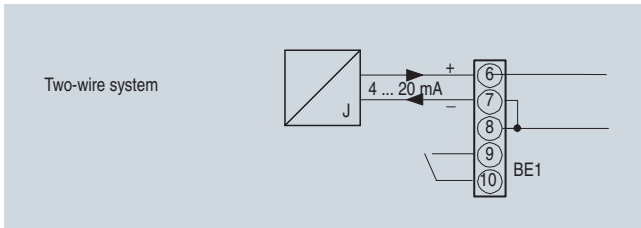

SIPART PS2 electropneumatic positioner, input circuit for 6DR50.. and 6DR51..

Electric connection of PROFIBUS PA device (6DR55..) and FOUNDATION Fieldbus devices (6DR56..)

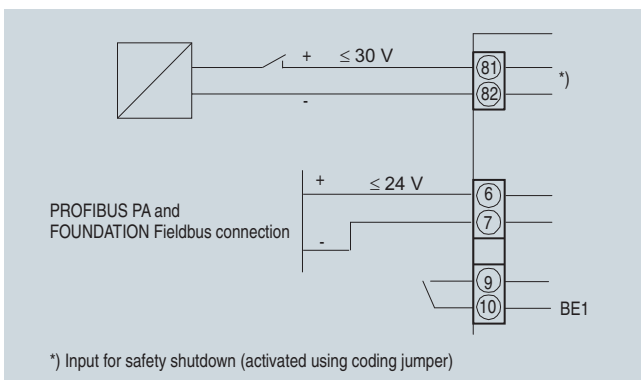

SIPART PS2 PA and SIPART PS2 FF electropneumatic positioner, input circuit for 6DR55.. and 6DR56..

Electric connection of 2-, 3- and 4-wire device (6DR52.. and 6DR53..)

Devices of types 6DR52.. and 6DR53.. can be operated in a 2-, 3- and 4-wire system.

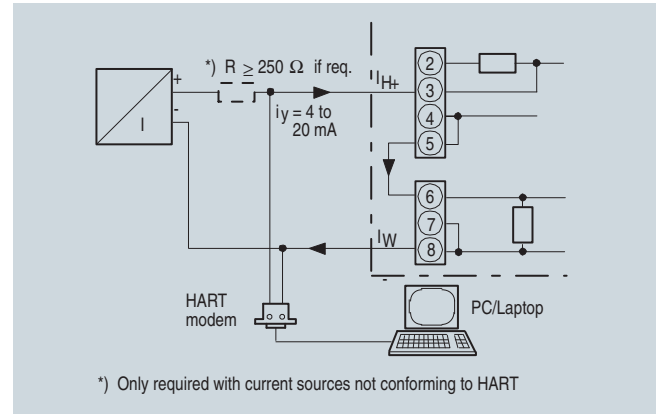

SIPART PS2 electropneumatic positioner, example of connection for communication through HART for 6DR52..

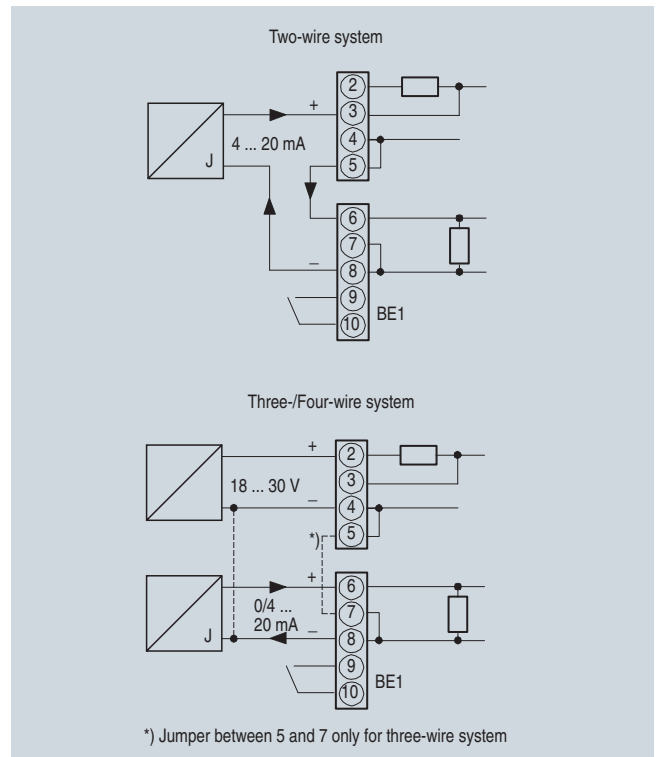

SIPART PS2 electropneumatic positioner, input circuits for 6DR52..

Electropneumatic positioners

SIPART PS2

Mounting kits

Mounting kit for NAMUR linear actuators

- 1 mounting bracket
- 2 mounting prisms
- 1 U-bracket
- 1 lever arm with adjustable pick-up roll
- 2 U-bolts
- Various screws and lock washers

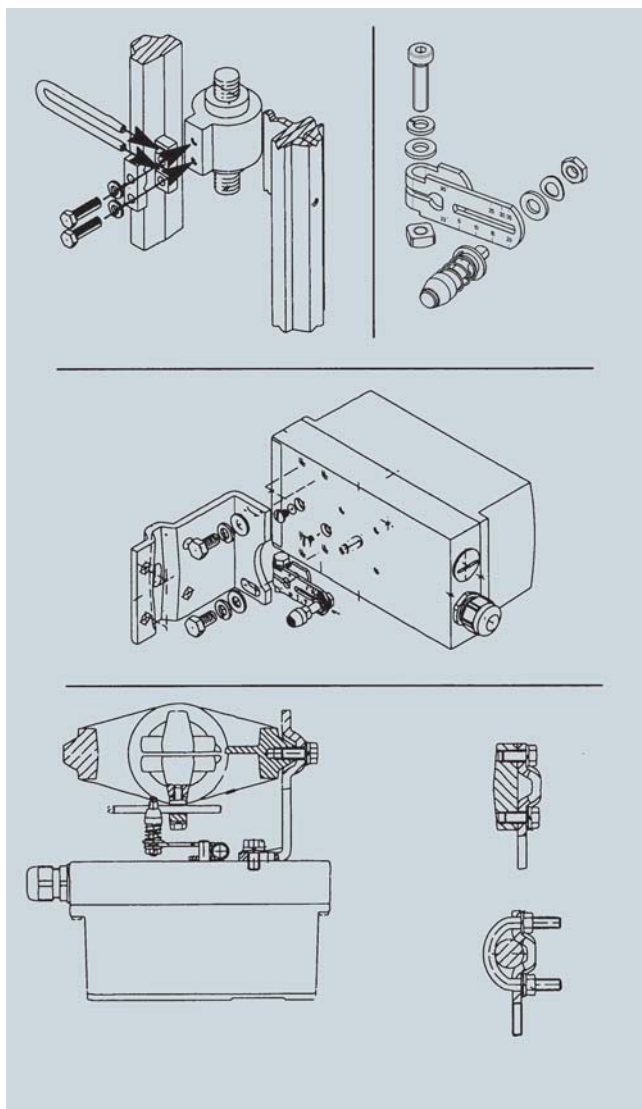

Mounting of SIPART PS2 on linear actuators

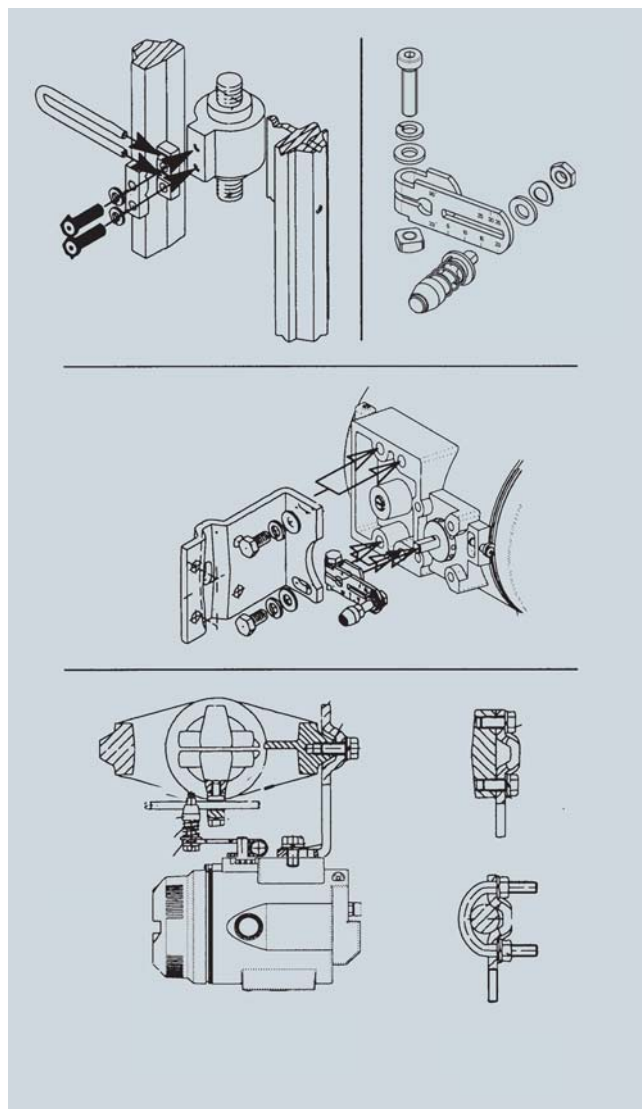

Mounting of SIPART PS2 EEx d on linear actuators

Mounting kit for NAMUR part-turn actuators

- 1 coupling wheel
- 1 driver pin
- 8 scales
- 1 pointer
- Various screws and lock washers

Caution: The mounting consoles and the screws for mounting onto the part-turn actuator are not included in the scope of delivery and must be provided by the customer (see Technical specifications).

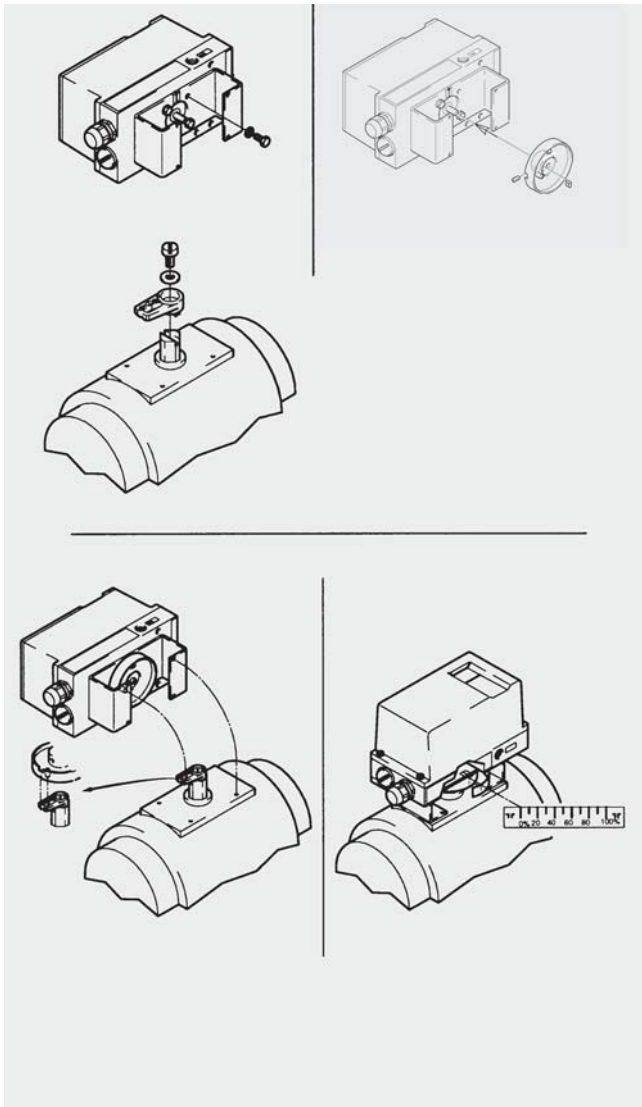

Mounting of SIPART PS2 on part-turn actuators

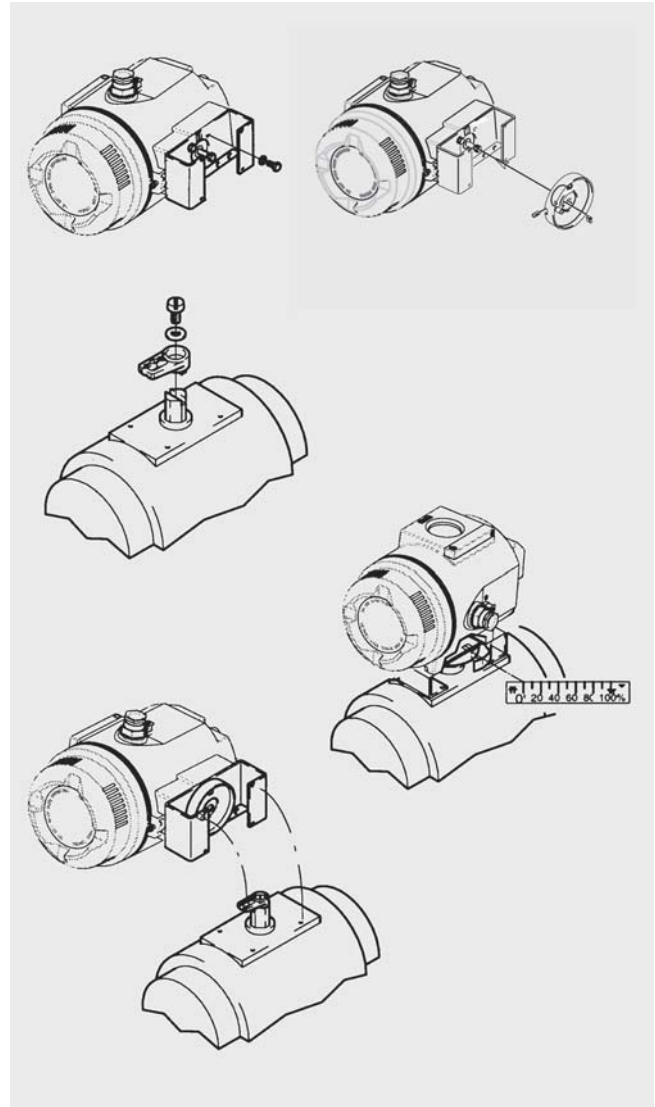

Mounting of SIPART PS2 EEx d on part-turn actuators

Electropneumatic positioners

