

SITRANS F flowmeters

SITRANS F US

System information and selection guide

Overview

Siemens offers two types of ultrasonic flowmeters, in-line flowmeters and clamp-on flowmeters. This offers the end user the maximum flexibility to choose the technology that best fits his needs. The following chapter shows the in-line versions.



SITRANS F US in-line ultrasonic flowmeters measure flow of electrically conductive and non-conductive liquids.

Application

In-line ultrasonic flowmeters are suitable for measuring the flow of liquids with good acoustic permeability, independent of conductivity, viscosity, temperature, density and pressure.

- max. 3% solids
- max. 3% air and gas
- max. 350 cSt

The main applications can be found in the following sectors:

- Raw water intake for water treatment plants
- Treated waste water
- Power generation and utility
- Oil and gas industry and petrochemical industry
- Irrigation systems
- Cooling water plants within the industry and in power stations
- Plants transporting non-conductive liquids
- HART/4 to 20 mA output
- PROFIBUS PA
- ATEX
- MODBUS

Benefits

SITRANS F US ultrasonic in-line flowmeters measure liquids with good acoustic permeability, independent of conductivity, viscosity, temperature, density and pressure.

- Sensor sizes from DN 50 to 1200 mm (2" to 48"), optional down to DN 25 (1")
- Standard with calibration certificate
- In-line retrofit as 1 and 2 track up to DN 4000 (160")
- Dedicated transmitter portfolio for HVAC, power generation, utility and general industry as well as more demanding applications
- Custody transfer approvals within district heating
- Compact and remote transmitter installation
- Comprehensive self-diagnostic for error indication and logging
- Exchange of the transducers without interrupting operation
- HART, PROFIBUS PA and MODBUS communication
- ATEX
- Mains or battery powered solutions
- Battery lifetime of up to 8 year

Please see Product selector on the Internet, since some constraints might be related to some of the features:
www.pia-selector.automation.siemens.com



SONO 3300/ FUS060	SONO 3100/ FUS060	SONOKIT/ FUS060	FUE380	FUS380	FUS880
7ME3300...	7ME3100...	7ME3210.../ 7ME3220...	7ME3410...	7ME3400	7ME...

Industry		SONO 3300/ FUS060	SONO 3100/ FUS060	SONOKIT/ FUS060	FUE380	FUS380	FUS880
Water, treated waste water		XXX	XX	XXX		XXX	XX
Irrigation		XX	XX	XXX		XXX	XXX
Utility, district heating water, cooling		XXX	XX	XXX	XXX	XXX	
Utility, district heating, CT approvals required					XXX	XXX	
Oil		XX	XXX	XX		X	
Cryogenic fluids (only on request)			XXX				
On- and Offshore applications		XX	XXX	XX		X	
Chemical		XXX	XXX	X			
Design							
Electronic compact mounted					●	●	
Electronic remote mounted		●	●	●	●	●	●
Replaceable transducers under pressure			●	●			
Retrofit on existing steel pipes/non-weldable				●			●
Transmitter enclosure							
Polyamid, IP67					●	●	●
Die-cast aluminium (painted), IP65		●	●	●			
Communication							
HART		●	●	●			
PROFIBUS PA		●	●	●			
MODBUS RTU / RS 232 and RS 485					●	●	●
Power supply							
3.6 V Battery					●	●	●
115 ... 230 V AC		●	●	●	●	●	●
115 ... 230 V AC and 3.6 V battery backup					●	●	●
24 V AC/DC		●	●	●			
Accuracy							
0.25% (with 4-track system on request)			●				
0.50%		●	●	●	●	●	●
Sensor design							
1 track ultrasonic measurement (special request)			● ¹⁾	● ³⁾			●
2 track ultrasonic measurement		●	●	●	●	●	●
4 track ultrasonic measurement			●	●			
Dimension							
DN 25 ... 40 ²⁾	1" ... 1½" ²⁾		● ¹⁾				
DN 50	2"	●	● ¹⁾		●	●	
DN 65	2½"	●	● ¹⁾		●	●	
DN 80	3"	●	● ¹⁾		●	●	
DN 100	4"	●	●	● ³⁾	●	●	
DN 125	5"	●	●	● ³⁾	●	●	
DN 150	6"	●	●	● ³⁾	●	●	
DN 200	8"	●	●	●	●	●	●
DN 225	9"	●	●	●	●	●	●
DN 250	10"	●	●	●	●	●	●
DN 300	12"	●	●	●	●	●	●
DN 350	14"		●	●	●	●	●
DN 400	16"		●	●	●	●	●
DN 500	20"		●	●	●	●	●
DN 600	24"		●	●	●	●	●
DN 700	28"		●	●	●	●	●

X = can be used, XX = often used, XXX = most often used, ● = available

¹⁾ Also available as 1-track solution on request (down to DN 25 (1"))

³⁾ SONOKIT 1-Track DN100 to DN2400 and 2-track DN200 to DN4000

²⁾ Only SONO 3100 1-track (special request)

SITRANS F flowmeters

SITRANS F US

System information and selection guide

Please see Product selector on the Internet, since some constraints might be related to some of the features:
www.pia-selector.automation.siemens.com



SONO 3300/ FUS060	SONO 3100/ FUS060	SONOKIT/ FUS060	FUE380	FUS380	FUS880
7ME3300...	7ME3100...	7ME3210.../ 7ME3220...	7ME3410...	7ME3400	7ME...

Dimension (continued)

DN 800	32"		●	●	●	●	●
DN 900	36"		●	●	●	●	●
DN 1000	40"		●	●	●	●	●
DN 1200	48"		●	●	●	●	●
DN 1400 ... 4000	54" ... 160"			● ³⁾			

Process connection

Flanges	●	●		●	●		
Flangeless (for weld-in)		●					

Flanges Norm

EN 1092-1	●	●		●	●		
EN 1759-1	●	●					
ANSI B16.5		●					

Pressure rating

PN 6			●				●
PN 10	●	●	●	●	●		
PN 16	●	●	●	●	●		
PN 25		●	●	●	●		
PN 40	●	●	●	●	●		
Class 150		●					
Class 300		●					
PN 160		● ⁴⁾					
Class 2500		● ⁴⁾					

Pipe, flange and transducer material

Carbon steel	●	●	●	●	●		
Stainless steel		●	●				
Die cast bronze				●	●		
Other materials		on request	on request				●

Media temperature

°C	°F						
-200	-328		● ^{1) 2) 4)}				
-20	-4		●	●			
-10	+14	●	●	●			
+2	+35.6	●	●	●		●	●
+60	+140	●	●	●	●	●	●
+120	+248	●	●	●	● ⁵⁾	● ⁵⁾	
+150	+302	●	●	●	● ⁶⁾	● ⁶⁾	
+160	+320	●	●	●	●	●	
+190	+374		●	●	●	●	
+200	+392		●	●	●	●	
+250	+482		● ⁴⁾				

Measuring principle

Transit time principle	●	●	●	●	●	●	●
------------------------	---	---	---	---	---	---	---

X = can be used, XX = often used, XXX = most often used, ● = available

¹⁾ Also available as 1-track solution on request (down to DN 25 (1"))

²⁾ Only SONO 3100 1-track (special request)

³⁾ SONOKIT 1-Track DN100 to DN2400 and 2-track DN200 to DN4000

⁴⁾ Only on special request

⁵⁾ compact

⁶⁾ Pipe material bronze brass

SITRANS F flowmeters

SITRANS F US

System information and selection guide

Please see Product selector on the Internet, since some constraints might be related to some of the features:
www.pia-selector.automation.siemens.com



SONO 3300/ FUS060	SONO 3100/ FUS060	SONOKIT/ FUS060	FUE380	FUS380	FUS880
7ME3300...	7ME3100...	7ME3210.../ 7ME3220...	7ME3410...	7ME3400	7ME...

Approvals

Custody transfer approval for energy metering

MID class 2				●		
EN 1434 class 2 (Heat meter approval)				●		
OIML R 75 class 2 (Heat meter approval)				●		
PTB, Germany				●		
Other country specific type approval available for:						
- Russia (GOSS/GOST)	●	●	●	●	●	
- Rumania	●	●	●	●	●	
- China				●		

Ex approval

Ex d ATEX		●	●			
Ex i ATEX	●	●	●			

X = can be used, **XX** = often used, **XXX** = most often used, ● = available

SITRANS F flowmeters

SITRANS F US

System information and selection guide

Function

Physical principle

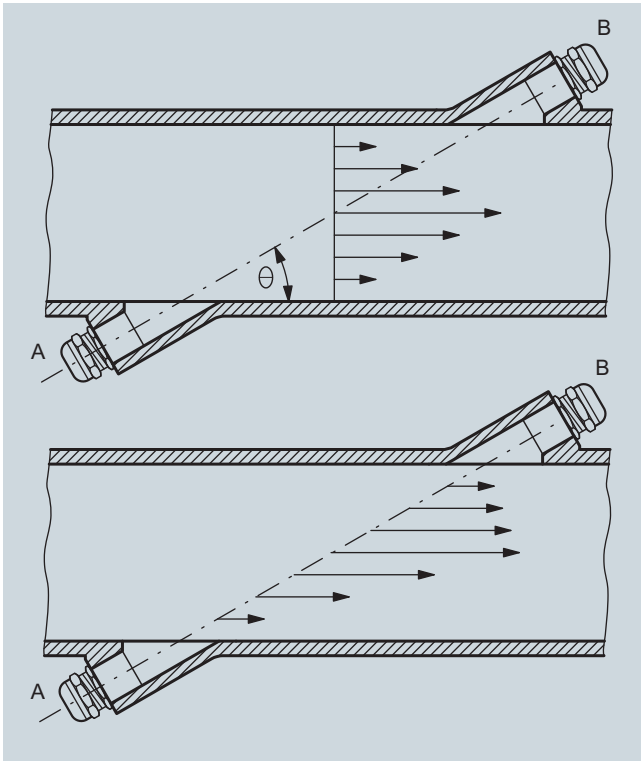

Velocity distribution along sound path

A sound wave traveling in the same direction as the liquid flow arrives at point B from point A in a shorter time than the sound wave traveling against the direction of flow (from point B to A). The difference in sound transit time indicates the flow velocity in the pipe.

Since delay time is measured at short intervals both in and against flow direction, viscosity and temperature have no influence on measurement accuracy.

Measuring principle

In SITRANS F US flowmeters the two ultrasonic transducers are placed at an angle θ in relation to the pipe axis. The transducers function as transmitters and receivers of the ultrasonic signals. Measurement is performed by determining the time the ultrasonic signal takes to travel with and against the flow. The principle can be expressed as follows:

$$v = K \cdot (t_{B,A} - t_{A,B}) / (t_{A,B} \cdot t_{B,A}) = K \cdot \Delta t / t^2$$

v = Average flow velocity

t = Transit time

K = Proportional flow factor

This measuring principle offers the advantage that it is independent of variations in the actual sound velocity of the liquid, i.e. independent of the temperature. Proportional factor K is determined by wet calibration.

Direct signal processing

The ultrasonic signal is sent directly and without deflection to the bore wall from the transmitter to the receiver. The advantage gained sending signals from point to point is an extremely good signal strength for the signal processing avoiding a suddenly flowmeter stop.

2-track solution

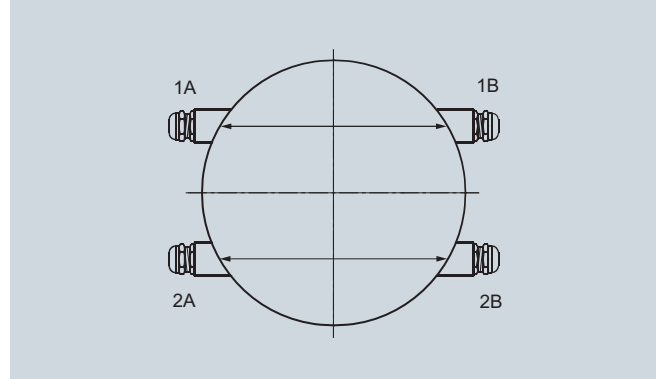

Ultrasonic 2-track flow meter with 4 transducers. In the upper track transducers 1A / 1B and in the lower track 2A / 2B are displayed.

The accuracy of ultrasonic flowmeters depends on the pipe geometry before and after the flowmeter and the number of ultrasonic measuring tracks.

When water flows through a pipe, it has a tendency to swirl and/or flow with different velocities inside the pipe, depending on the pipe design.

A 2-track ultrasonic flowmeter offers:

- less sensitivity to upstream obstruction like bends, pumps or valves.
- high security in the measurements as the meter continues to measure even if, for some reason, one track stops working.

Typical straight inlet requirements are upstream $10 \times D_i$ (D_i = diameter of the flowmeter) and downstream $3 \times D_i$.

Typical accuracy that can be reached with 2-track ultrasonic flowmetering is $\pm 0.5\%$ with installations according to above demands.

4-track ultrasonic flowmeters

Some applications require accuracy under extreme short inlet conditions and swirl that cannot be obtained with 2-track solutions.

For these applications we can offer a 4-track solution – customer specified – according to actual inlet conditions.

Please contact Siemens Flow Instruments for specific applications.

Technical specifications

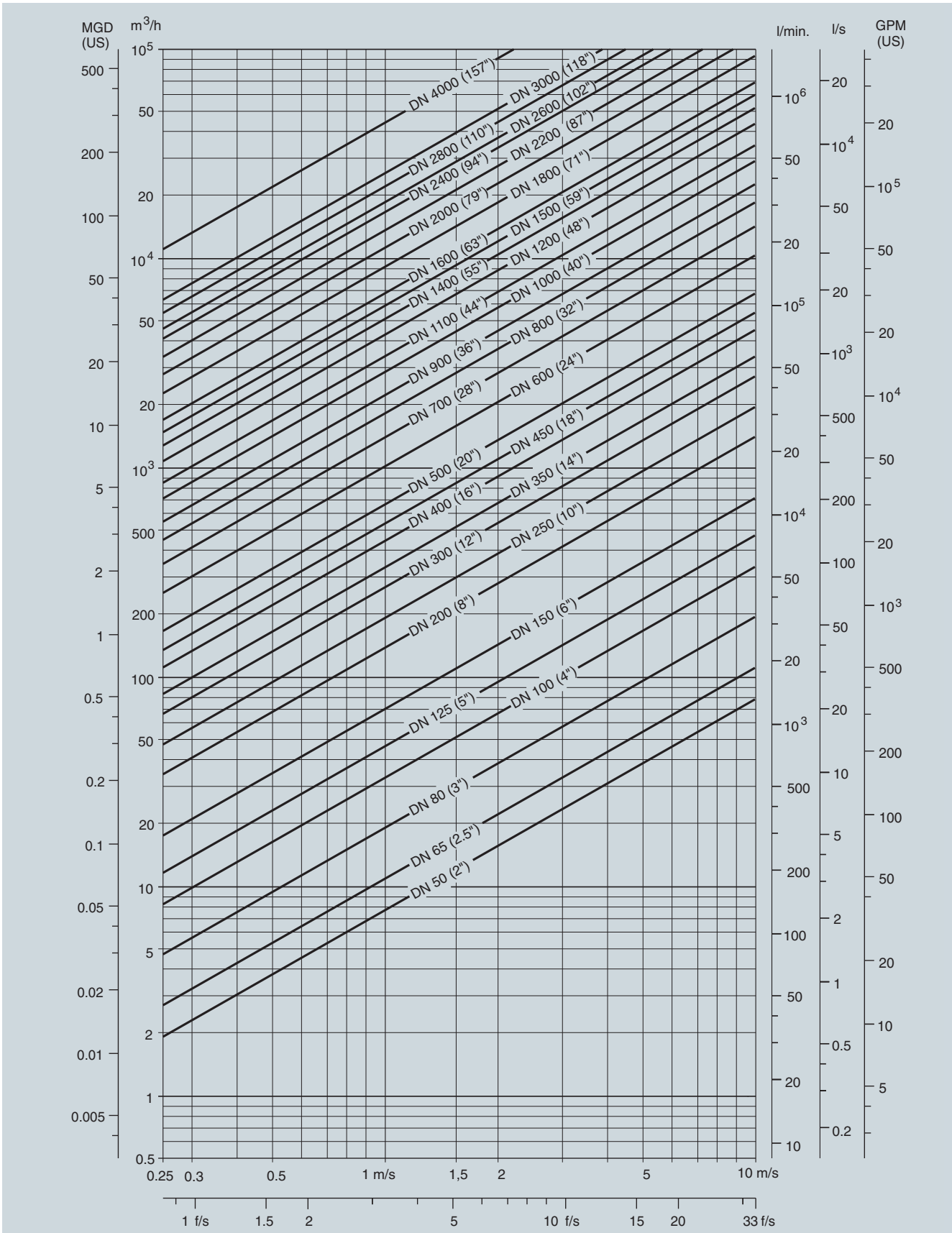

Nominal size and flow

SITRANS F flowmeters

SITRANS F US

System information and selection guide

Guidelines for selection of sensor

- Min. measuring range: 0 ... 0.25 m/s
- Max. measuring range: 0 ... 10 m/s

Normally nominal flow velocity is within the measuring range 1 ... 3 m/s.

Flow velocity calculation formula:

- $v = (4 \times Q_{\max}) / (\pi \times D_i^2 \times 3600)$
- v in m/s, Q_{\max} in m³/h, D_i in m

Inlet and outlet conditions

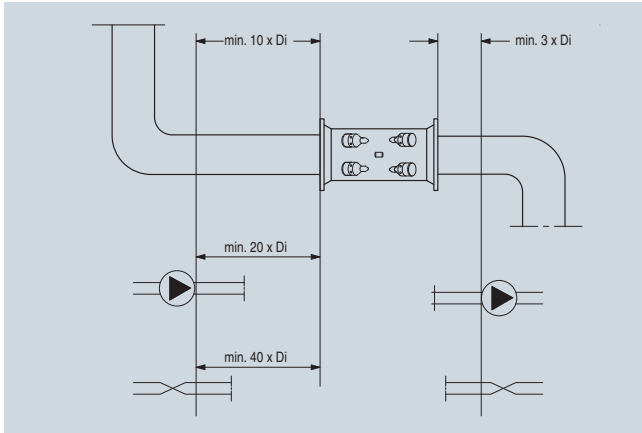

Recommended inlets and outlets

To maximize performance inlet and outlet must be straight. There must be a certain distance between flowmeter and bends, pumps and valves. It is also important to centre the flowmeter in relation to pipe flanges and gaskets.

Valves must always be installed after the flowmeter. The only exception is installation of the sensor in a vertical pipe. In this case a valve below the sensor is necessary to allow zero point adjustment. It is important to select a valve which does not alter the flow when fully open.

Recommended inlet/outlet

	SONO 3300, SONO 3100, SONOKIT 2-track	FUS380/FUE380 ¹⁾	SONOKIT 1-track
90° bend	10 x D _i	10 x D _i	20 x D _i
Fully opened valve	10 x D _i	10 x D _i	20 x D _i
Partially opened valve	40 x D _i	40 x D _i	40 x D _i
2 x 90° bends in same plane	15 x D _i	15 x D _i	25 x D _i
2 x 90° bends in two planes	20 x D _i	20 x D _i	40 x D _i
Outlet	3 x D _i	3 x D _i	3 x D _i

¹⁾ Inlet for FUE380 with MID approval should be for sizes ≥ DN 80: 1.5 m

The sensor must always be completely filled with liquid:

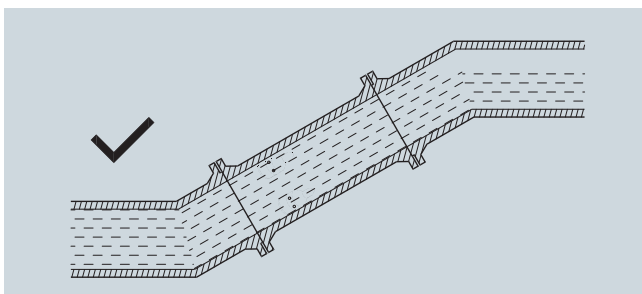

The following installations should be avoided:

- Installation at the highest point of the pipe system
- Installation in vertical pipes with free outlet

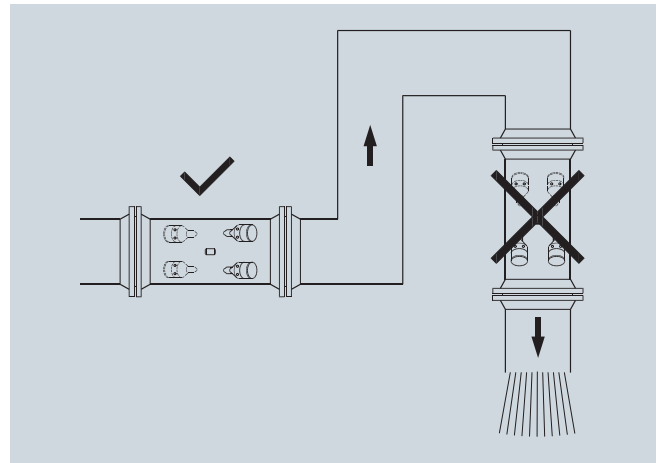
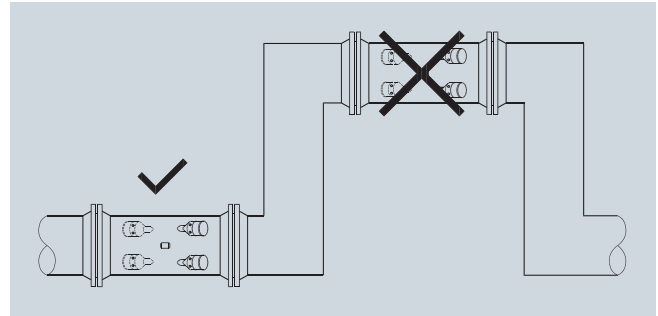

With partially full pipes or pipes with free outlet the flowmeter should be located in a U-shaped tube:

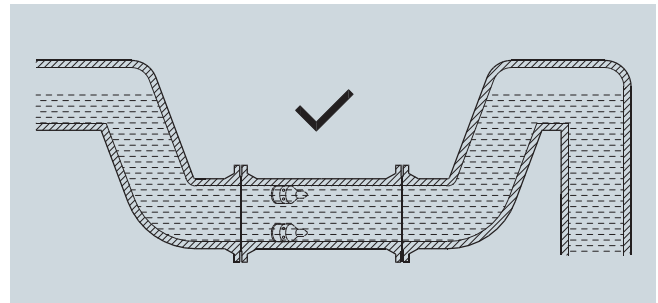

Installing the transducers in horizontal position is recommended:

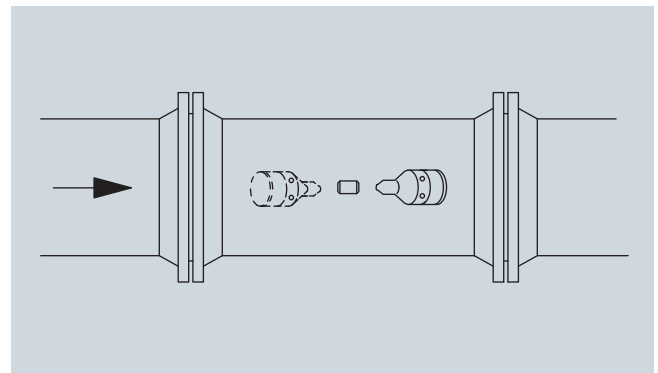

Pressure-temperature curve to EN (DIN) flanges

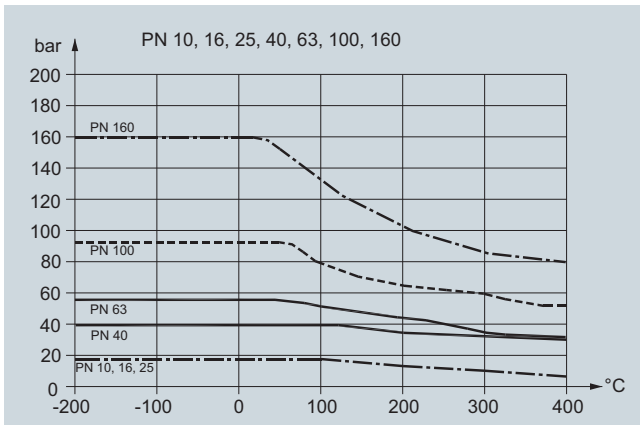

Pressure-temperature curve to ANSI B16.5 flanges

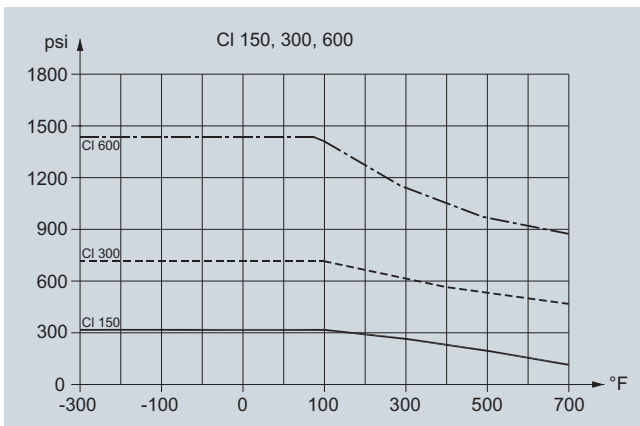

Note: The pressure-temperature curves only assist in the selection of a system. No responsibility is taken for the correctness of the information. For exact data please refer to the PED requirements.

Reference conditions

To ensure maximum accuracy sensor and transmitter must be calibrated together.

Flowmeter calibration data are stored in the internal EPROM of the transmitters FUS060 or FUS080.

The system accuracy refers to the following systems:

SONO 3300/FUS060, SONO 3100/FUS060¹⁾.

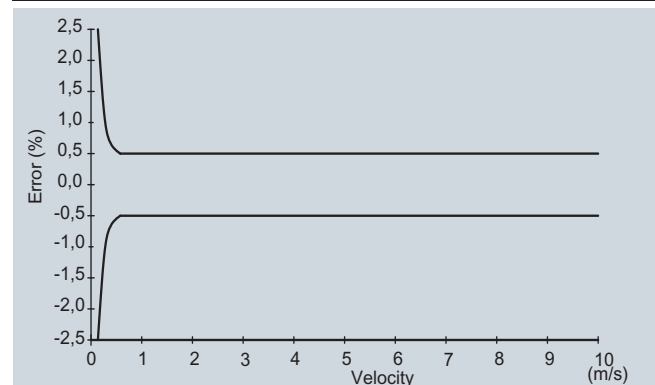

Fluid	Water
Fluid temperature	22 ± 5 °C
Ambient temperature	22 ± 5 °C
Supply voltage	AC 115/230 V +10 ... -15% DC 24 V +25 ... -15%, AC 24 V ±15%
Straight inlet length	20 x D _i
Rangeability	0 ... 1 m/s to 0 ... 10 m/s
Repeatability	Better than 0.25% in the range 0.5 ... 10 m/s
Linearity	
• Reynolds number 1000 < Re < 5000	Better than 1%
• Reynolds number > 5000	Better than 0.5%

¹⁾ Only systems with transmitter FUS060. For systems with transmitter FUS080 see chapter to FUS380 and FUE380.

Additional effects of deviations from reference conditions

- Current output: As frequency output (± 0.1% of actual flow +0.05% FSO)
- Effect of ambient temperature: Frequency/pulse output: < 0.005% SPAN/K
- Current output: < ± 0.0075% SPAN/K
- Effect of supply voltage: 0.005% of measuring value at 1% change