

CA Series

Wideband, high current devices for protection of radio transmitters and receivers connected to coaxial feeders

- **Large bandwidth dc to 2GHz**
- **Robust - 10kA surge rating**
- **Range of connector styles to suit all applications**
- **DC coupled**
- **Low insertion loss and VSWR**
- **Tested in accordance with BS6651:1999**



The CA Series of surge protection devices prevents surges and transient over-voltages conducted through coaxial cables from damaging electronic systems such as telemetry outstations. They protect vulnerable equipment without affecting normal operation, passing high frequency signals with little attenuation while diverting surge currents safely to earth and clamping output voltages to safe levels.

Typical applications for the CA Series include the protection of radio telemetry systems, mobile communications base stations and, where high induced voltages may be present, in aerial systems.

Receivers & transmitters are particularly vulnerable to damage from the effects of lightning. Their remote locations and physical construction make them a likely target for lightning activity. The use of semiconductors and integrated circuits in transmitters and

receivers has rendered them particularly prone to damage from these disturbances.

Excellent performance levels are achieved using high energy gas discharge tubes, in precision engineered compact enclosures, to produce superior surge suppression and transmission characteristics. The protection circuitry is capable of diverting 10kA impulses whilst the brass bodies and connectors are silver plated and are designed to meet harsh environmental requirements.

A wide range of connector types are available (including BNC, N-type, TNC, UHF and F-type) to suit all application requirements. In addition, bulkhead mounting options are provided for where insertion into a panel is preferable. Models are supplied with a choice of working voltage and characteristic impedance (90V, 150V and 350V) are provided for most units in the range.

Mounting kits and enclosures to simplify installation, are available for the CA Series. Panel mounting can be achieved using the MC range of mounting brackets, or, for a larger number of units, the MK range of busbar mounting kits can be supplied (for mounting up to 20 units). IP65 weather-proof enclosures are also available to suit every application.

Typical Performance

Limiting voltage

When choosing a surge protection device it is important to determine the limiting voltage for a given surge level. Figure 1 shows the effectiveness of the CA350 series for a 6kV overvoltage. The limiting voltage shows the level of surge 'let-through' the surge protection device - in this case just over 600V for a fraction of a microsecond and represents a very small amount of energy.

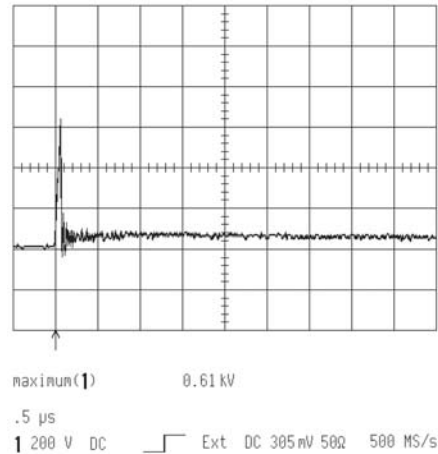

Figure 1 Typical limiting voltage for the CA350

Attenuation characteristics

The inclusion of a surge protection device should have minimal effect on a system other than to safeguard vulnerable equipment. The attenuation plot shown in figure 2 emphasises how little the system is changed after fitting a CA series SPD.

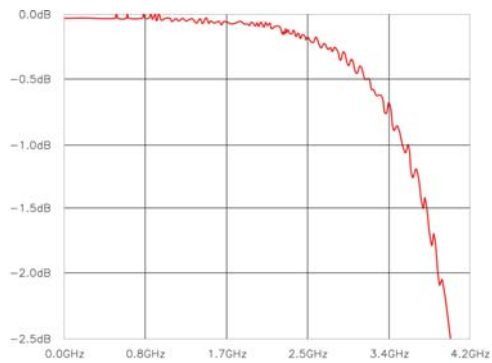

Figure 2 Typical attenuation plot for N-type CA devices

Return Loss

Figure 3 shows the return loss for the N-type variant of the CA series.

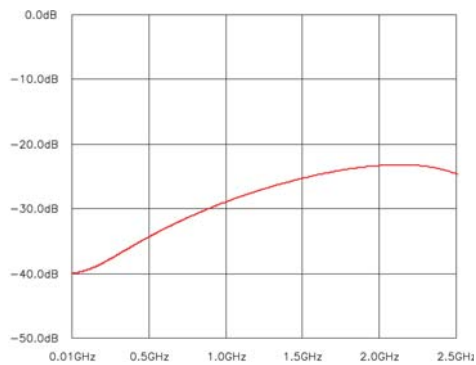

Figure 3 Typical return loss for N-type CA devices

Equivalent circuit

An equivalent circuit model of the CAxx/N is illustrated in figure 4. This model gives reasonable agreement with measured frequency response to 4.2GHz and return loss to 2.5GHz.

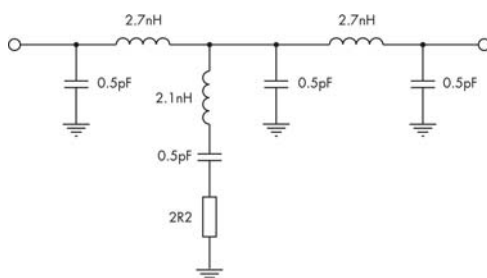

Figure 4 Equivalent circuit diagram

Installation

Figure 5 shows a typical remote telemetry unit (RTU). Signals are passed to the transmitter via data cabling, shown here as a 4-20mA loop. AC power for the transmitter enters the bottom of the RTU shed.

For optimum protection it is essential to employ surge protection devices where cabling enters the RTU building. The antenna feed connects directly to a CA Series SPD and then into the transmitter using a short cable link. The CA is mounted onto an MK2 mounting kit and an earth connection using at least 2.5mm² cable is taken from the MK2 earth stud to the RTU electrical earth, typically the enclosure earth stud. This cable length should be kept to a minimum to reduce the voltage drop across it during surge conditions.

Data lines should be protected using an SD series surge protector. These mount onto DIN rail and provide an automatic, high integrity earth connection via the DIN rail. Mains powered equipment can be protected using the MA Range of AC power SPDs.

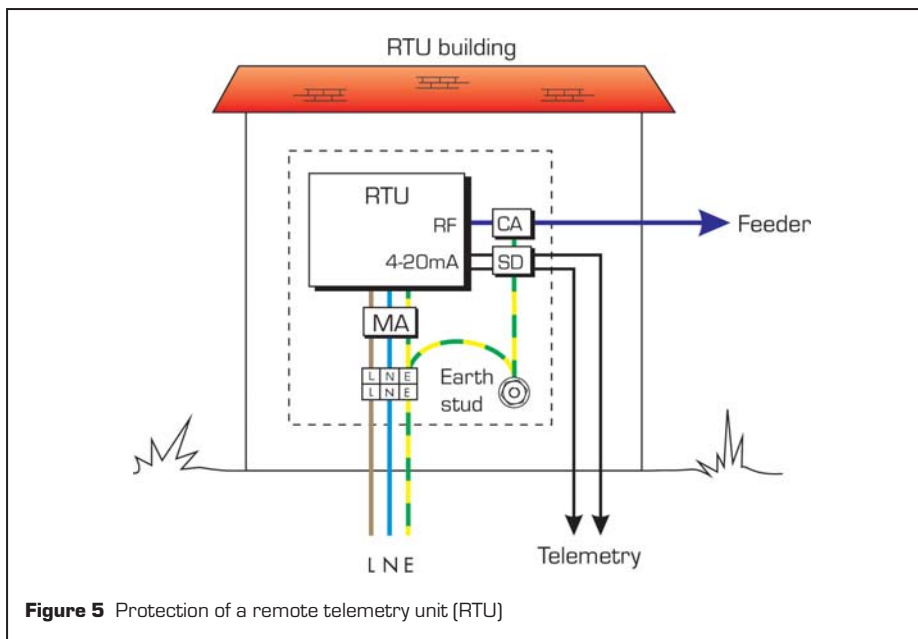

CA Series Mounting Kits and Enclosures

The CA series has a full range of mounting kits and enclosures to simplify installation. Telematic offers a choice of enclosures to suit every application. Panel mounting can be achieved using either the MC range of mounting brackets or, for a larger number of units, the MK range of busbar mounting kits.

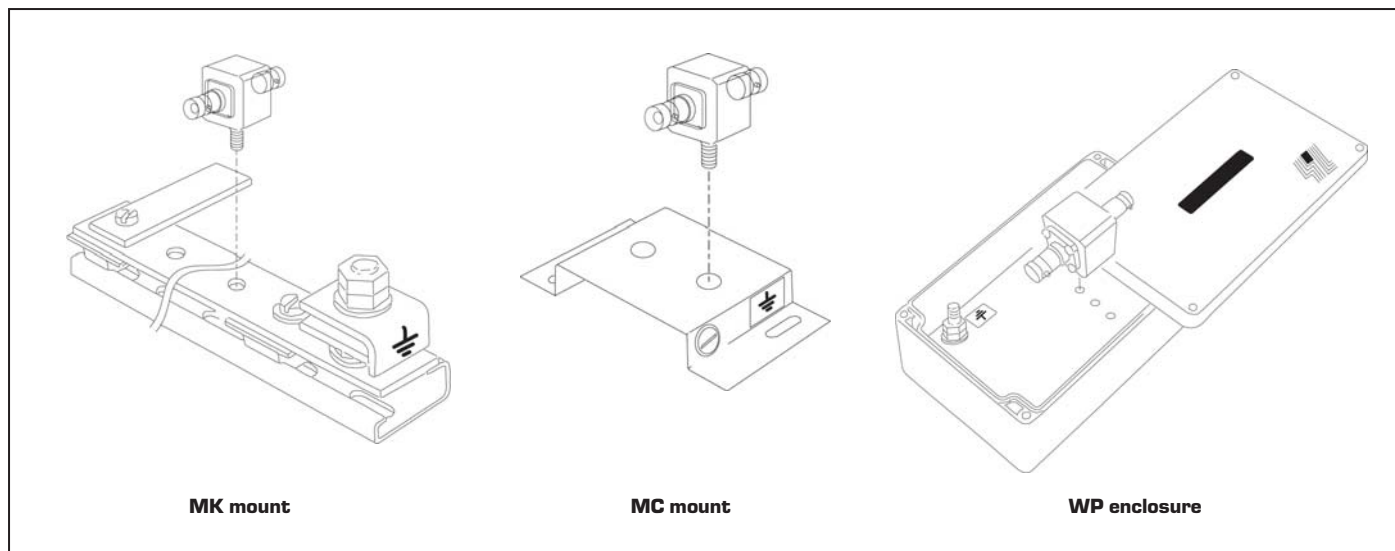

Mounting options

- MC1** mounting bracket for 1 CA device
- MC2** mounting bracket for up to 2 CA devices
- MK2** mounting kit for up to 2 CA devices
- MK5** mounting kit for up to 5 CA devices
- MK10** mounting kit for up to 10 CA devices

Weatherproof enclosures

- WP3** Polycarbonate to IP65, holds 3 CA devices
- WP5** Polycarbonate to IP65, holds 5 CA devices
- WP12** Polycarbonate to IP65, holds 12 CA devices

Specification

All figures typical at 77°F (25°C) unless otherwise stated

Maximum discharge current (inner to screen)

10kA 8/20µs pulse (to IEC 61000-4-5)

Maximum power rating (VSWR = 1, no AM)

DC Sparkover (V)	Maximum transmit Power (W) Zo=50 ohm	Maximum transmit Power (W) Zo=75 ohm
90	45	30
350	784	523

Limiting voltage

600V (6kV/3kA)

Bandwidth

2GHz

De-rating for VSWR

Derate the applied power by a factor of

$$\left(\frac{1}{1+D}\right)^2$$

where D is the reflection coefficient

Additional de-rating for AM

Derate the applied power by a factor of

$$\left(\frac{1}{1+p}\right)^2$$

where D is the modulation depth

Inner to shield capacitance

< 1pF

Ingress protection (BS EN 60529)

IP65

Temperature Range

-40°C to +85°C

Weight

BNC	95g
N-Type	130g
TNC	95g
UHF	100g
F-type	95g
Bulkhead N-type	150g

Dimensions

See figure 6

Corrosion resistance

Silver plated connectors and bodies are standard and stainless steel nuts, screws and washers are used throughout.

Please note

All products are supplied with female connectors as standard.

There are a number of variants within the CA range.

Detailed technical performance data for each device can be supplied on request.

Note: In accordance with our policy of continuous improvement, we reserve the right to change the product's specification without notice.

For more information please contact your local MTL sales office:

The Americas:	+1 800 835 7075
UK:	+44 (0)1582 723633
Singapore:	+65 6 487 7887
The Netherlands:	+31 (0)481 450250
Italy:	+39 (0)2 6180 2011
Australia:	+61 (0)8 9455 2994
India:	+91 (0)44 450 1660

Local sales office information is also available on our web site at:
www.mtlsurge.com/support/distribution/index.htm

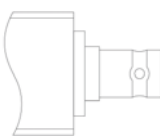
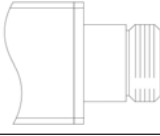
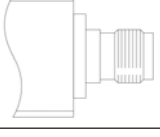
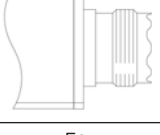
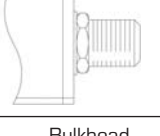
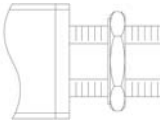
Style	Voltage	Impedance	Maximum Frequency (MHz)	Typical Insertion	Product Name
 BNC	90	50 75	1000	<0.1	CA90/B/50 CA90/B/75
	350	50 75	1000	<0.1	CA350/B/50 CA350/B/75
 N-type	90	50 75	2000	<0.2	CA90/N/50 CA90/N/75
	350	50 75	2000	<0.05	CA350/N/50 CA350/N/75
 TNC	90	50 75	1000	<0.1	CA90/T/50 CA90/T/75
 UHF	90	50	2000	<0.1	CA90/U/50
	350	50	2000	<0.05	CA350/U/50
 F-type	90	75 (nominal)	1000	<0.1	CA90/F
 Bulkhead N-type	90	50	2000	<0.2	CA90/N/50/B
	350	50	2000	<0.05	CA350/N/50/B

* Information available on request.

